

# GOBLIN

## HELICOPTER

# MANUAL

## GOBLIN URUKAY CARBON



- Carefully check your model before each flight to ensure it is airworthy.
- Consider flying only in areas dedicated to the use of model helicopters.
- Check and inspect the flying area to ensure it is clear of people obstacles.
- Rotor blades can rotate at very high speeds! Be aware of the danger they pose.
- Always keep the model at a safe distance from other pilots and spectators.
- Avoid maneuvers with trajectories towards a crowd.
- Always maintain a safe distance from the model.



SAB HELI DIVISION

## **Goblin URUKAY CARBON Manual**

Release 1.1 - November 2016

### **WORLD DISTRIBUTION**

[www.goblin-helicopter.com](http://www.goblin-helicopter.com)

For sales inquiries, please email: [sales@goblin-helicopter.com](mailto:sales@goblin-helicopter.com)

For info inquiries, please email: [support@goblin-helicopter.com](mailto:support@goblin-helicopter.com)

Attention: If you are a consumer and have questions or need of assistance,  
please contact in a first time the Goblin retailer where you made the purchase

### **EUROPEAN DISTRIBUTION**

[www.sabitaly.it](http://www.sabitaly.it)

For sales inquiries, please email: [sales@sabitaly.it](mailto:sales@sabitaly.it)

For info inquiries, please email: [info@sabitaly.it](mailto:info@sabitaly.it)

Attention: If you are a consumer and have questions or need of assistance,  
please contact in a first time the Goblin retailer where you made the purchase

Please read this user manual carefully, it contains instructions for the correct assembly of the model.  
Please refer to the web site [www.goblin-helicopter.com](http://www.goblin-helicopter.com) for updates and other important information.

## VERY IMPORTANT

In the Manual bag you will find a product card your with serial number. Please take a moment to register your kit online via our web site at:

<http://www.goblin-helicopter.com>



It is extremely important that you take a moment to register your helicopter with us. This is the only way to ensure that you are properly informed about changes to your kit, such as upgrades, retrofits and other important developments. SAB Heli Division cannot be held responsible for issues arising with your model and will not provide support unless you register your serial number.

The Serial number is also engraved in the Aluminum Main Plate.

*Thank you for your purchase, we hope you enjoy your new Goblin helicopter!*

SAB Heli Division

## INDEX

- |                              |   |                                       |
|------------------------------|---|---------------------------------------|
| 1 – Specifications           | 7 – Assembling The Modules                  | 13 – Installation of the Boom, Canopy |
| <b>2 – Important Notes</b> ⚠ | 8 – Installation of Swashplate Servos       | 14 – Battery                          |
| 3 – Components and Box       | 9 – Installation of The Motor               | <b>15 – In flight</b> ⚠               |
| 4 – Carbon frame Assembly    | 10 – Installation of The ESC                | 16 – Maintenance                      |
| 5 – Trasmission Assembly     | 11 – Installation of Flybarless Unit and RX | 17 – Exploded Views                   |
| 6 – Main Rotor HF3C          | 12 – Tail Assembly                          | 18 – Spare Parts                      |

## SPECIFICATIONS

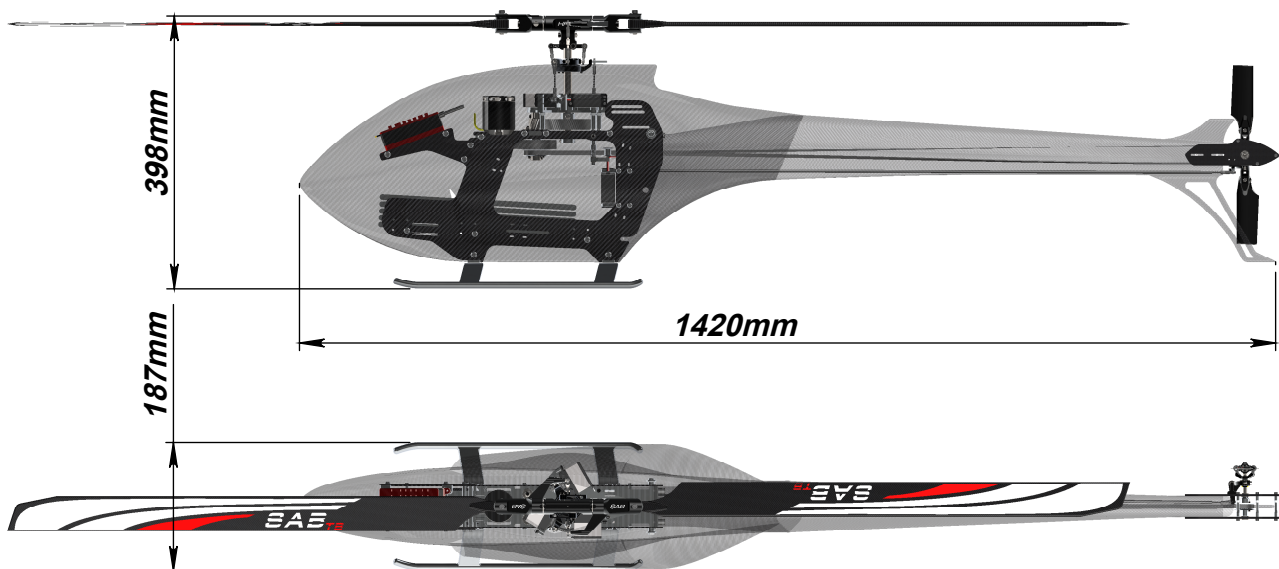

Main rotor diameter: 1654mm with 730mm blades.  
Main blade length: up to 750mm  
Tail rotor diameter: 304mm ( 284mm for EG version )  
Tail blade length: 115mm ( 105mm for EG version )  
Main shaft diameter: 12mm  
Tail shaft diameter: 6mm  
Spindle diameter: 10mm  
Motor size: Maximum 64mm diameter, maximum height 72mm  
Battery compartment: 60x58x350mm (adaptable to 75x58x350mm)



**IMPORTANT NOTES**

- \*This radio controlled helicopter is not a toy.
- \*This radio controlled helicopter can be very dangerous.
- \*This radio controlled helicopter is a technically complex device which has to be built and handled very carefully.
- \*This radio controlled helicopter must be built following these instructions. This manual provides the necessary information to correctly assemble the model. It is necessary to carefully follow all the instructions.
- \*Inexperienced pilots must be monitored by expert pilots.
- \*All operators must wear safety glasses and take appropriate safety precautions.
- \*A radio controlled helicopter must only be used in open spaces without obstacles, and far enough from people to minimize the possibility of accidents or of injury to property or persons.
- \*A radio controlled helicopter can behave in an unexpected manner, causing loss of control of the model, making it very dangerous.
- \*Lack of care with assembly or maintenance can result in an unreliable and dangerous model.

**\*Neither SAB Heli Division nor its agents have any control over the assembly, maintenance and use of this product. Therefore, no responsibility can be traced back to the manufacturer. You hereby agree to release SAB Heli Division from any responsibility or liability arising from the use of this product.**

**SAFETY GUIDELINES**

- \*Fly only in areas dedicated to the use of model helicopters.
- \*Follow all control procedures for the radio frequency system.
- \*It is necessary that you know your radio system well. Check all functions of the transmitter before every flight.
- \*The blades of the model rotate at a very high speed; be aware of the danger they pose and the damage they may cause.
- \*Never fly in the vicinity of other people.

**LIMITED WARRANTY.**

SAB Heli Division reserves the right to change or modify this warranty without notice and disclaims all other warranties, express or implied.

**(a)** This warranty is limited to the original Purchaser ("Purchaser") and is not transferable. REPLACEMENT AS PROVIDED UNDER THIS WARRANTY IS THE EXCLUSIVE REMEDY OF THE PURCHASER This warranty covers only those Products purchased from an authorized SAB Heli Division dealer. Third party transactions are not covered by this warranty. Proof of purchase is required for warranty claims.

**(b)** Limitations- SAB HELI DIVISION MAKES NO WARRANTY OR REPRESENTATION, EXPRESS OR IMPLIED, ABOUT NONINFRINGEMENT, MERCHANTABILITY OR FITNESS FOR A PARTICULAR PURPOSE OF THE PRODUCT. THE PURCHASER ACKNOWLEDGES THAT THEY ALONE HAVE DETERMINED THAT THE PRODUCT WILL SUITABLY MEET THE REQUIREMENTS OF THE PURCHASER'S INTENDED USE.

**(c)** Purchaser Remedy- SAB Heli Division's sole obligation hereunder shall be that SAB Heli Division will, at its option, replace any Product determined by SAB Heli Division to be defective In the event of a defect, this is the Purchaser's exclusive remedy. Replacement decisions are at the sole discretion of SAB Heli Division. This warranty does not cover cosmetic damage or damage due to acts of God, accident, misuse, abuse, negligence, commercial use, or modification of or to any part of the Product. This warranty does not cover damage due to improper installation, operation, maintenance or attempted repair by anyone

**DAMAGE LIMITS.**

SAB HELI DIVISION SHALL NOT BE LIABLE FOR SPECIAL, INDIRECT OR CONSEQUENTIAL DAMAGES, LOSS OF PROFITS OR PRODUCTION OR COMMERCIAL LOSS IN ANY WAY CONNECTED WITH THE PRODUCT, WHETHER SUCH CLAIM IS BASED IN CONTRACT, WARRANTY, NEGLIGENCE, OR STRICT LIABILITY. Further, in no event shall the liability of SAB Heli Division exceed the individual price of the Product on which liability is asserted. As SAB Heli Division has no control over use, setup, final assembly, modification or misuse, no liability shall be assumed nor accepted for any resulting damage or injury. By the act of use, setup or assembly the user accepts all resulting liability. If you as the Purchaser or user are not prepared to accept the liability associated with the use of this Product, you are advised to return this Product immediately in new and unused condition to the place of purchase.

**NOTES FOR ASSEMBLY**

Please refer to this manual for assembly instructions for this model. Follow the order of assembly indicated. The instructions are divided into chapters, which are structured in a way that each step is based on the work done in the previous step. Changing the order of assembly may result in additional or unnecessary steps. Use thread lockers and retaining compounds as indicated. In general, each bolt or screw that engages with a metal part requires thread lock. It is necessary to pay attention to the symbols listed below:



**Important**



Indicates that for this assembly phase you need materials that are in Bag xx.



Use retaining compound (eg Loctite 648)



Use retaining compound (eg Loctite 243)



Use CA Glue



Use Proper Lubricant

**ADDITIONAL COMPONENTS REQUIRED**

- \*Electric Motor: 400 - 560Kv  
Maximum diameter 64mm,  
Maximum height 72mm,  
Pinion shaft diameter 6/8mm
- \*Speed controller: minimum 120A , suggest 160A
- \*Batteries: 12S-5000 mAh
- \*1 flybarless 3 axis control unit
- \*Radio power system, if not integrated with the ESC
- \*3 cyclic servos
- \*1 tail rotor servo
- \*6 channel radio control system on 2.4 GHz

(See configuration examples on page 17)

**TOOLS, LUBRICANTS, ADHESIVES**

- \*Generic pliers
- \*Hexagonal driver, size 1.5,2,2.5,3,4mm
- \*4mm T-Wrench
- \*5.5mm Socket wrench (for M3 nuts)
- \*8mm Hex fork wrench (for M5 nuts)
- \*Medium threadlocker (eg. Loctite 243)
- \*Strong retaining compound (eg. Loctite 648)
- \*Spray lubricant (eg. Try-Flow Oil)
- \*Grease ( eg. Microlube GL261 )
- \*Cyanoacrylate adhesive
- \*Pitch Gauge (for set-up)
- \*Soldering equipment (for motor wiring)

Inside the main box there are:

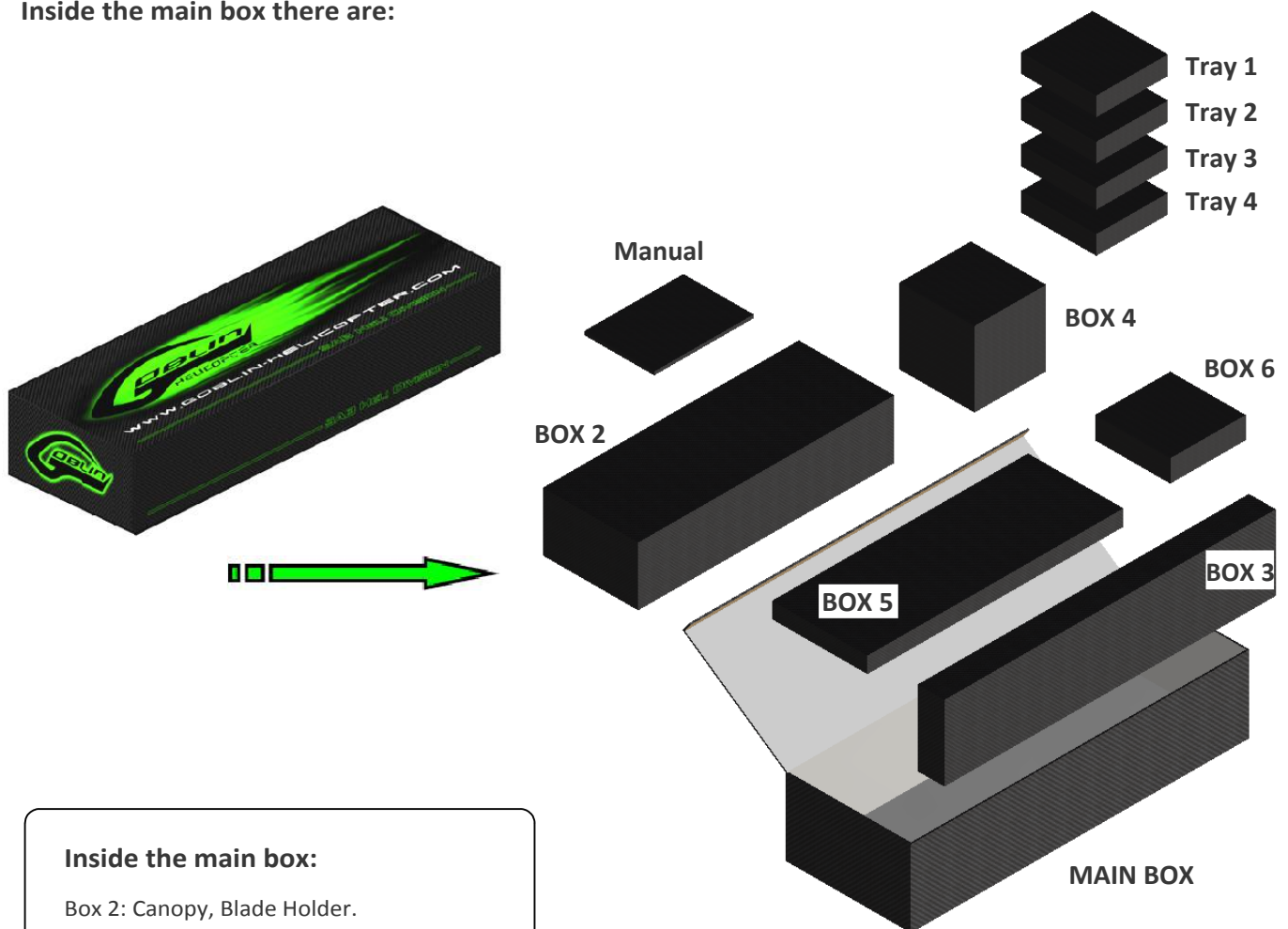

**Inside the main box:**

Box 2: Canopy, Blade Holder.

Box 3: Boom, Carbon rod, Blades.

Box 4: Mechanical parts in 4 trays:  
Tray 1: Main rotor.  
Tray 2: Carbon frame and tail rotor.  
Tray 3: Transmission.  
Tray 4: Main structure.

Box 5: Bags, Carbon parts.

Box 6: Tail Fin, Tail Blades.

The assembly process is described in the following chapters. Each chapter provides you with the box, bag and/or foam tray numbers you will need for that chapter. The information is printed in a green box in the upper right hand corner of the page at the beginning of every chapter.

# 4-Carbon Frame

 The manufacturing process of the carbon parts often leaves micro-burrs and sharp edges. We recommend de-burring the edges to minimize the risks of electrical wire cuts, etc. Very important in red line zone.

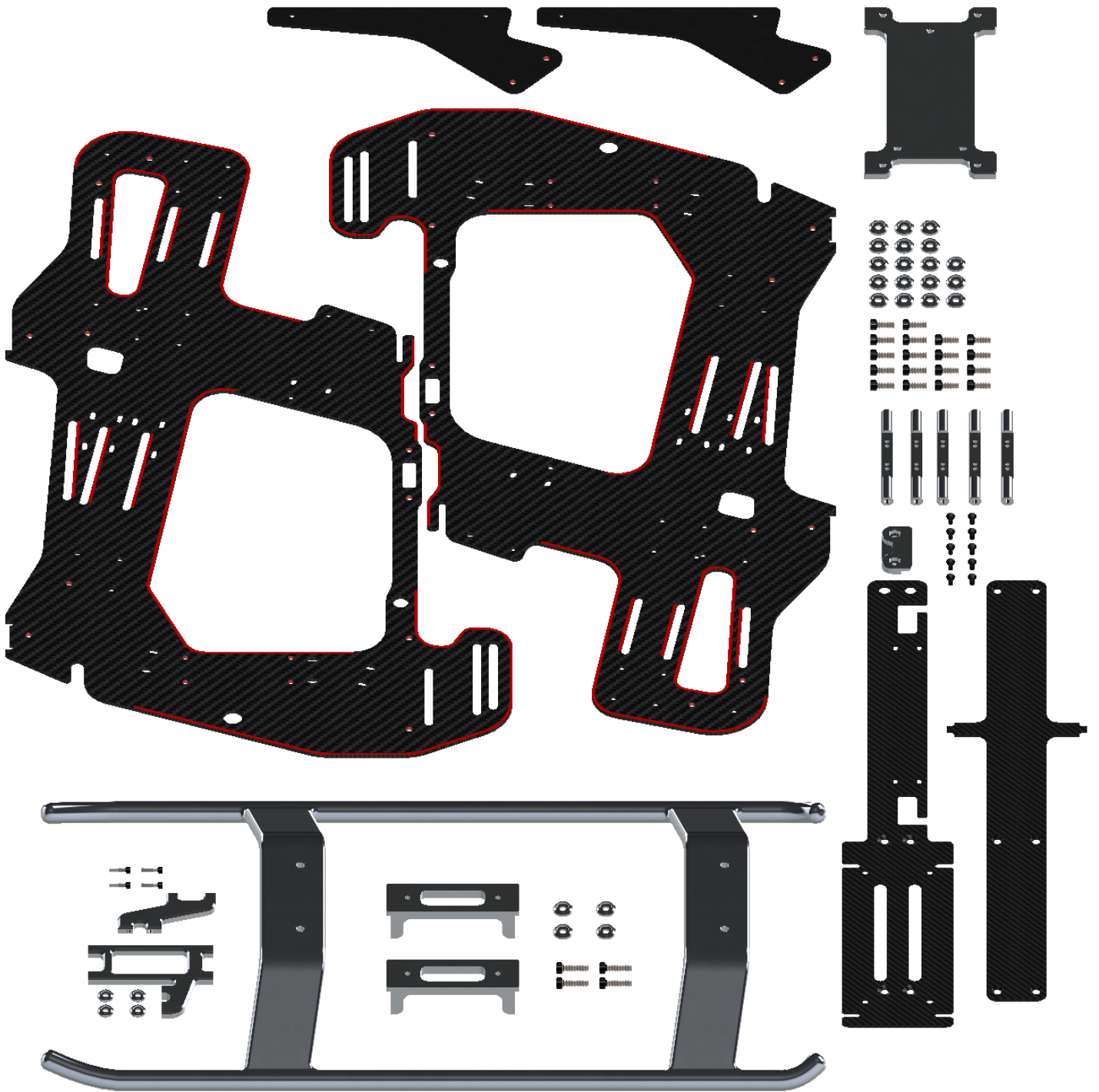

### Battery / ESC Position

It is possible to place the battery support in many positions.  
The two main positions are illustrated.

( Light Batteries < 1500-1600g )

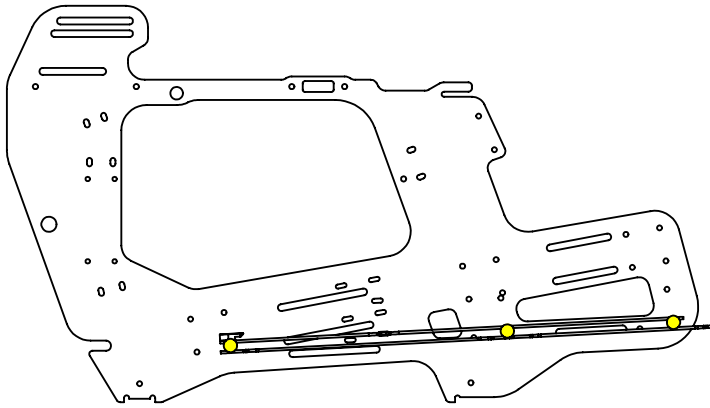

( Heavy Batteries > 1600-1700g )

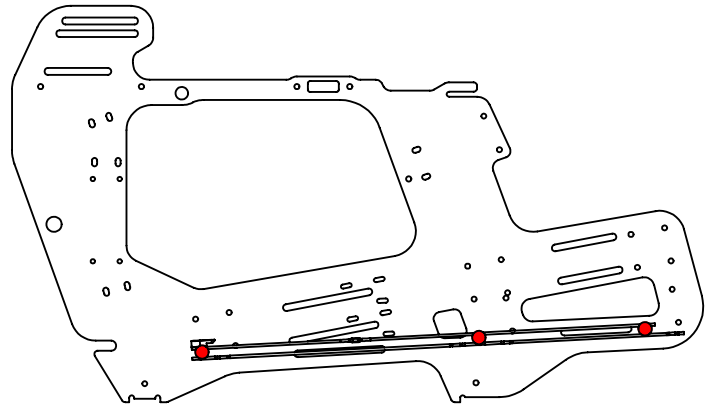

Here is showed another position. It allow you to raise the center of gravity of the model.

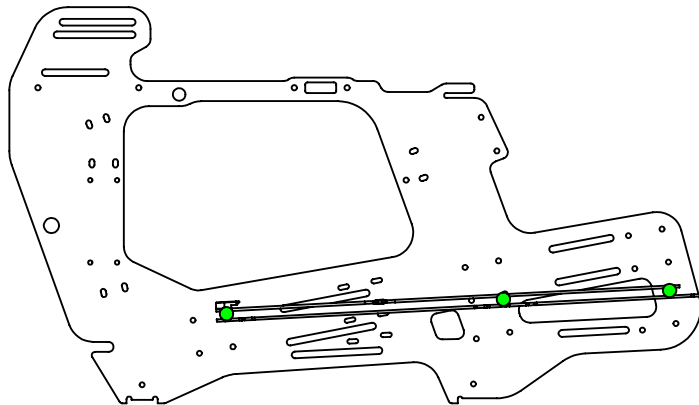

The three previous positions are in relation to the position "top" of the ESC. If you want, you can install the ESC in a bottom position ( Please see page 19 ).

In this case you have to install the battery support in the one of these.

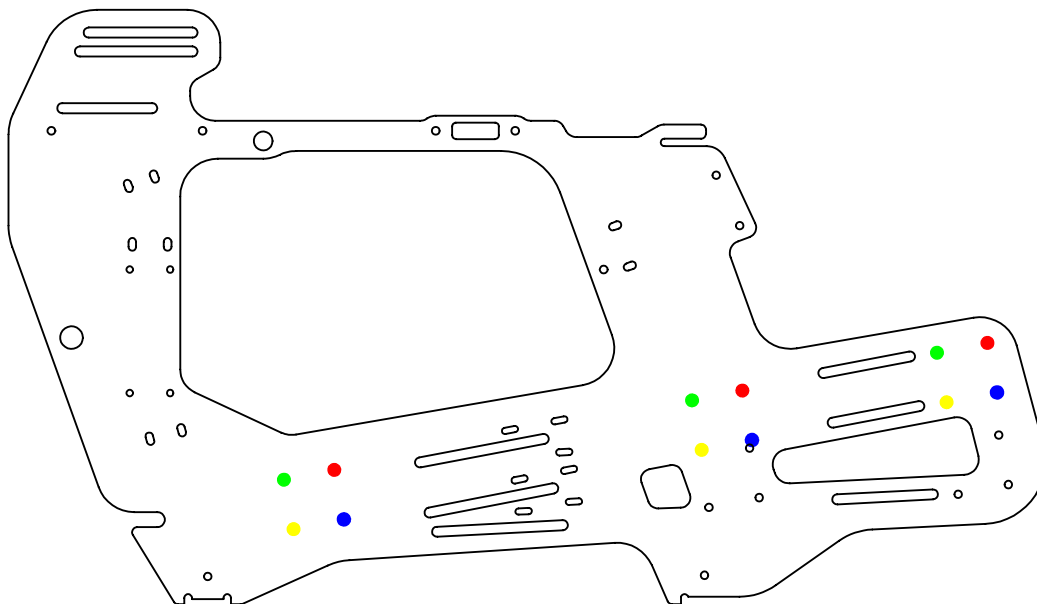



**Battery Tray Assembly**

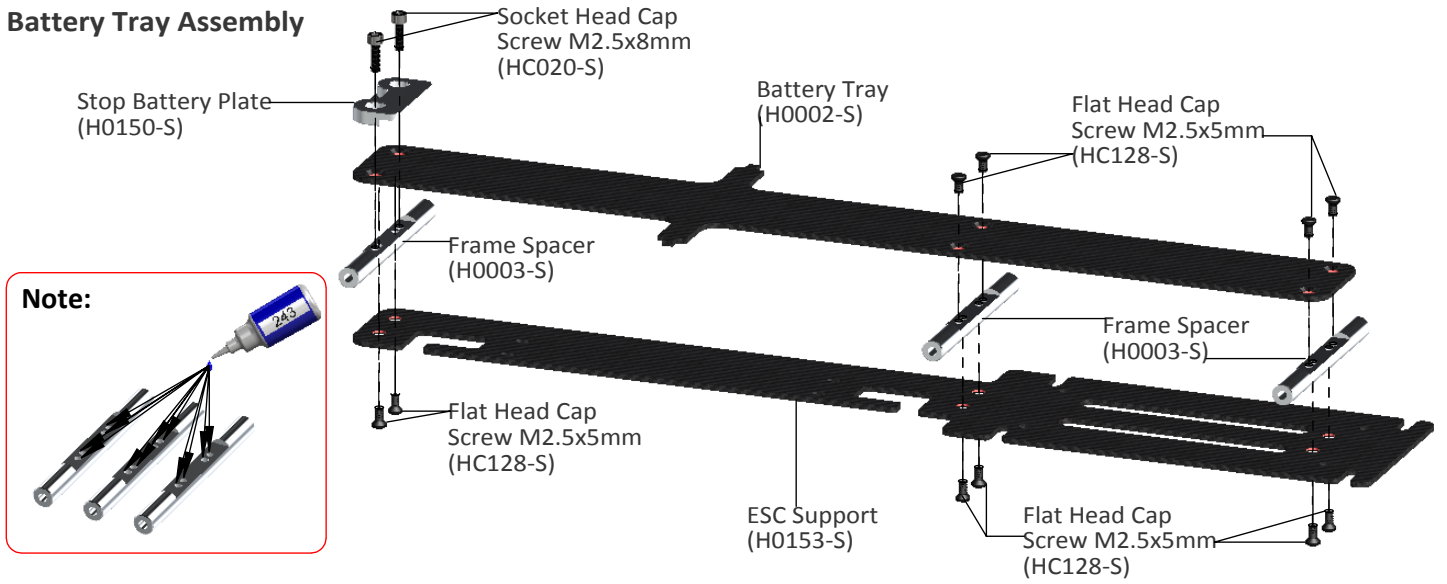

**Left Main Frame Assembly**

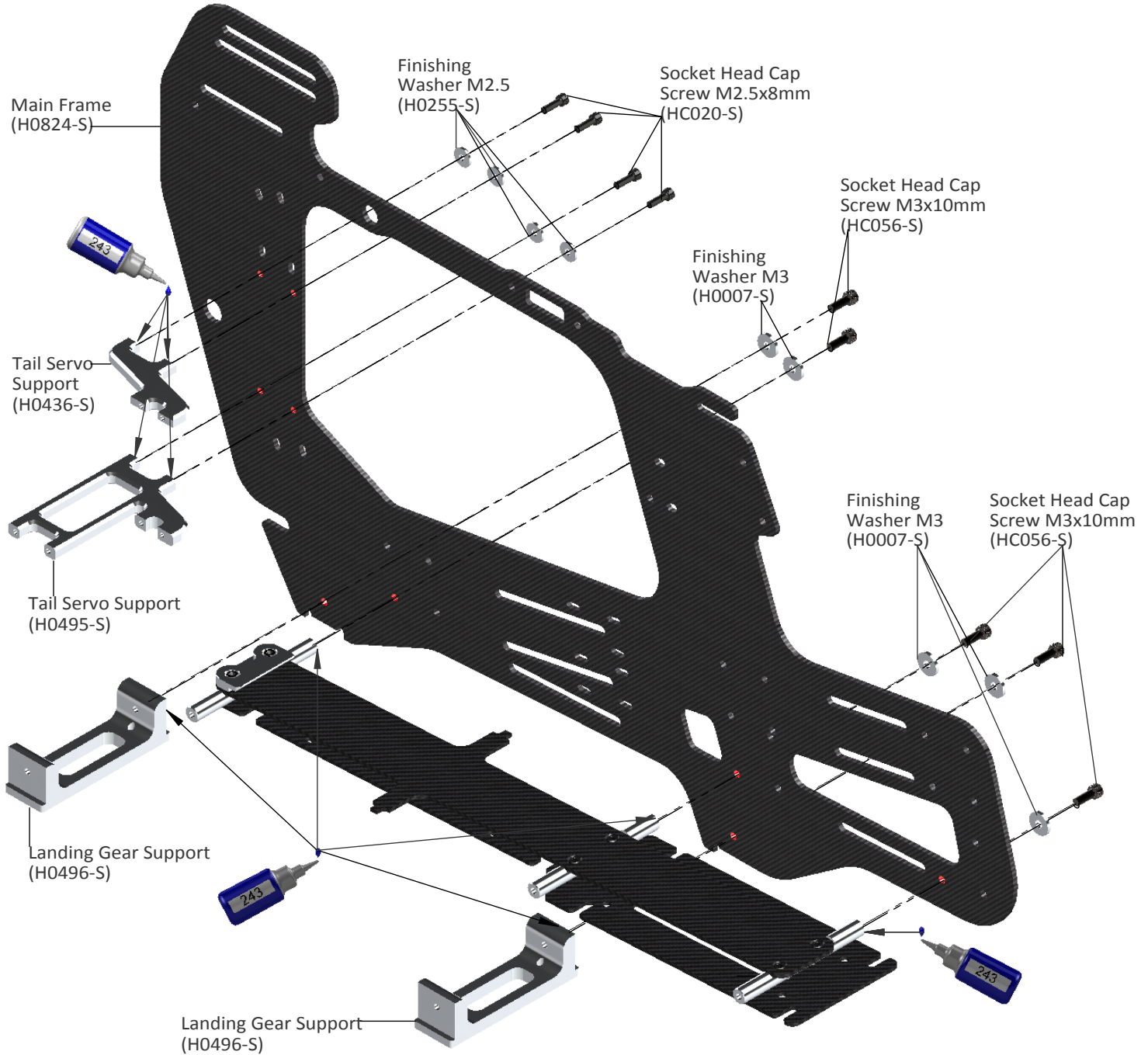



Carbon Frame Assembly

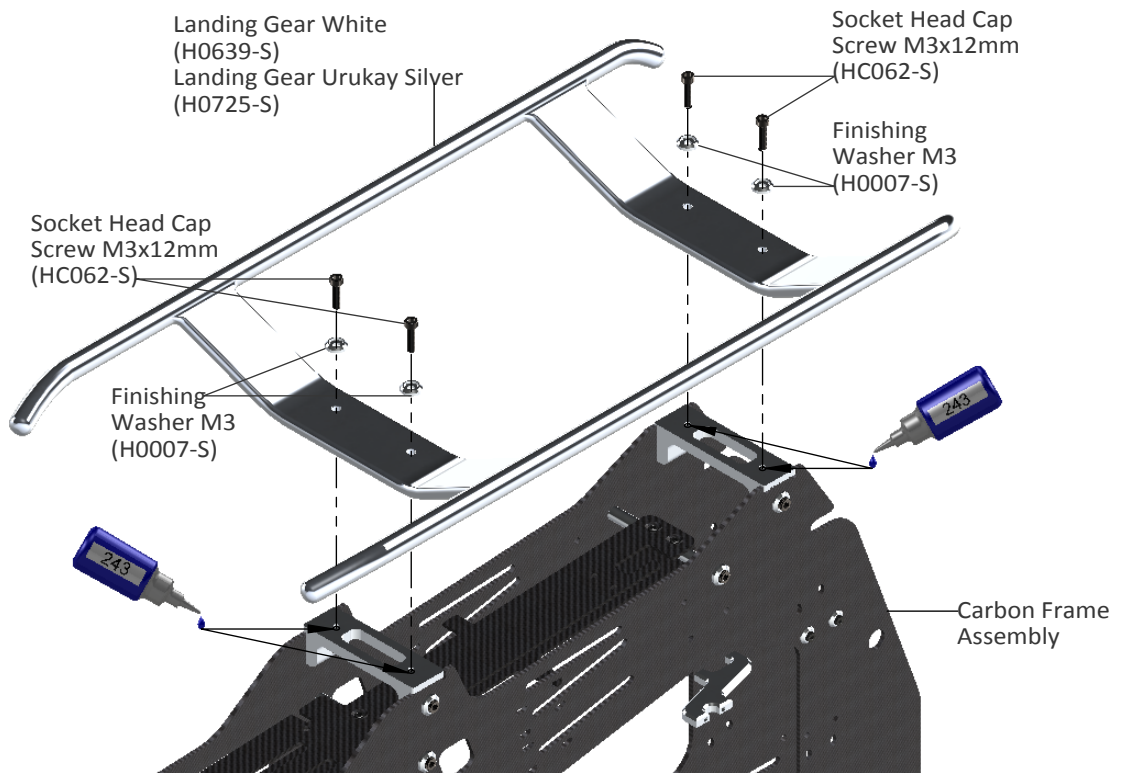
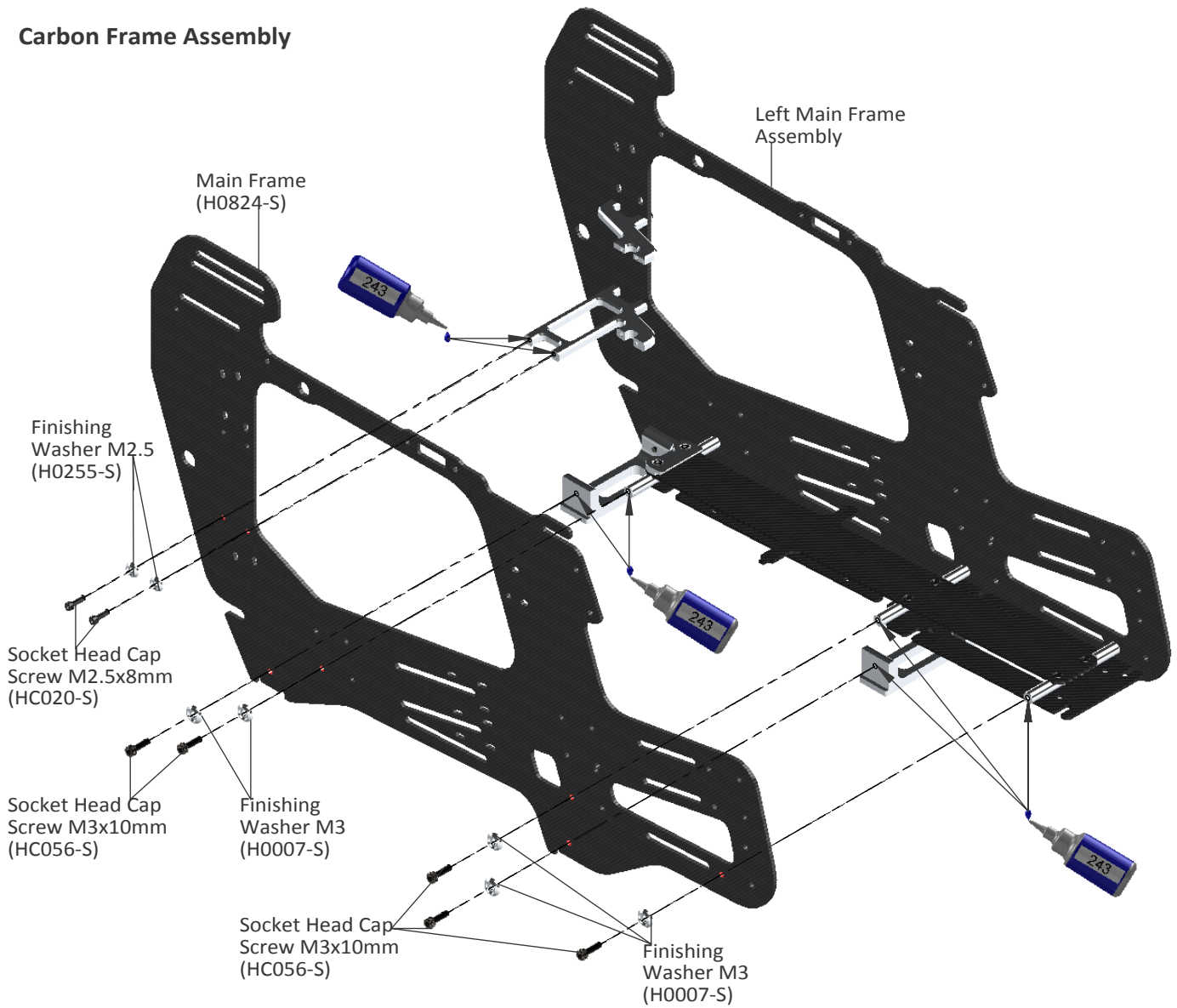

**Top ESC Support Assembly**

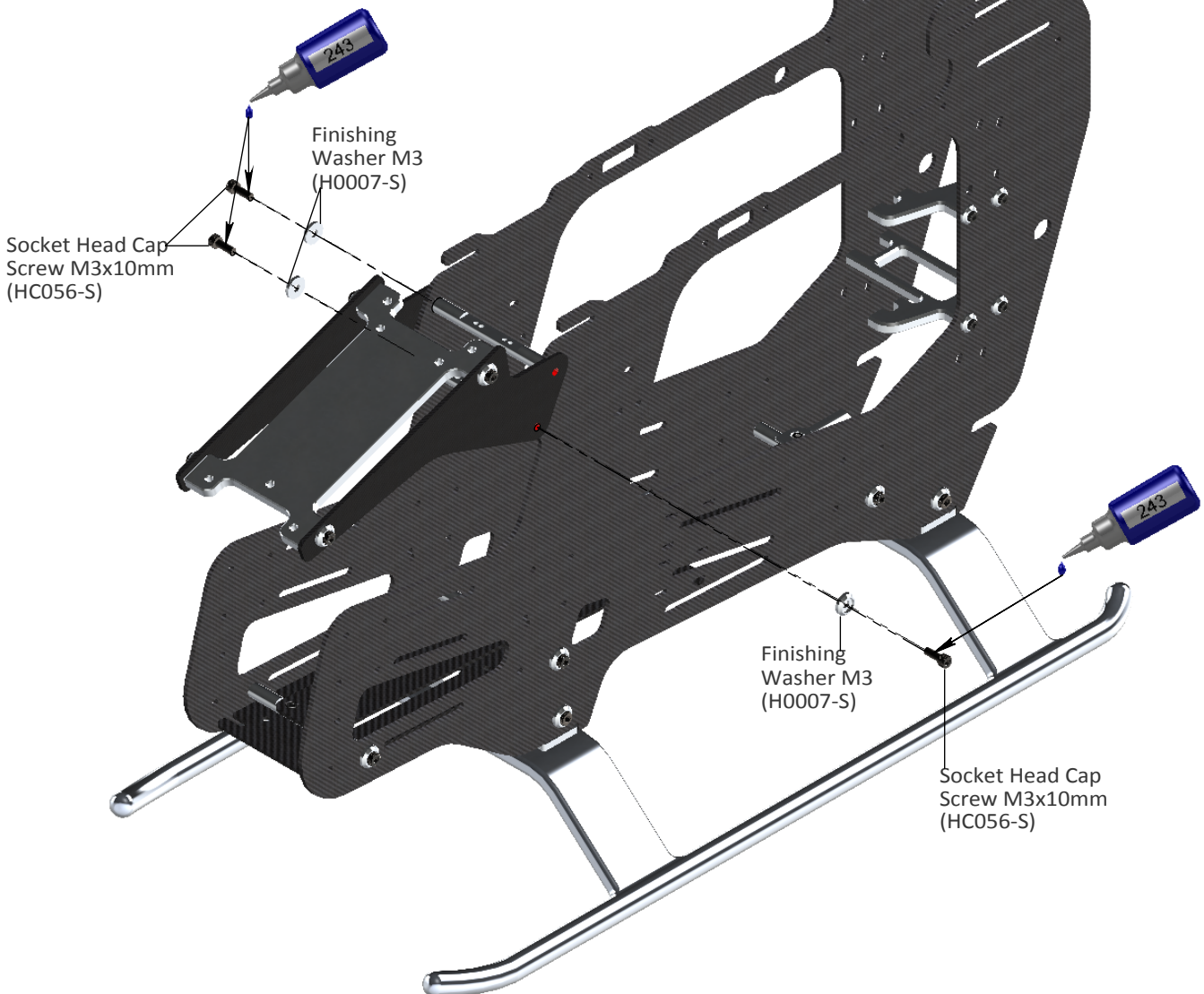
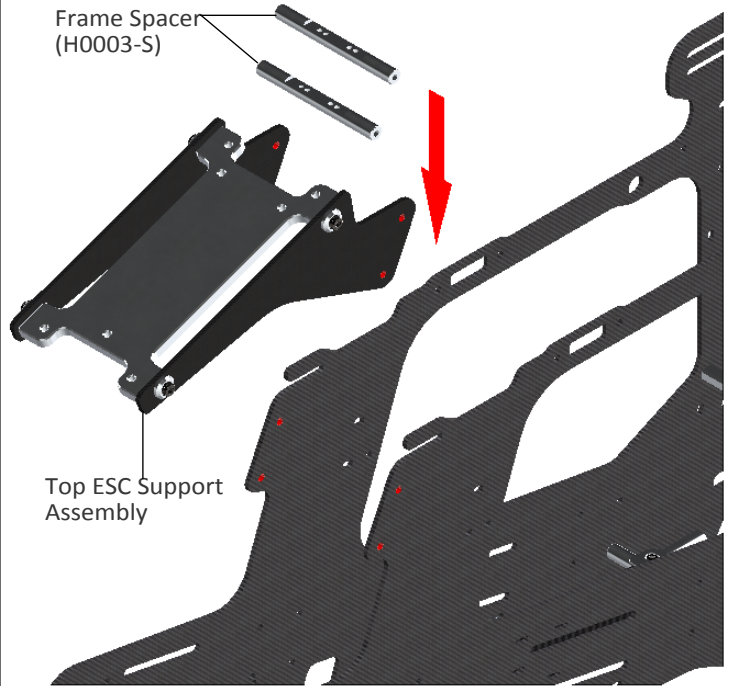
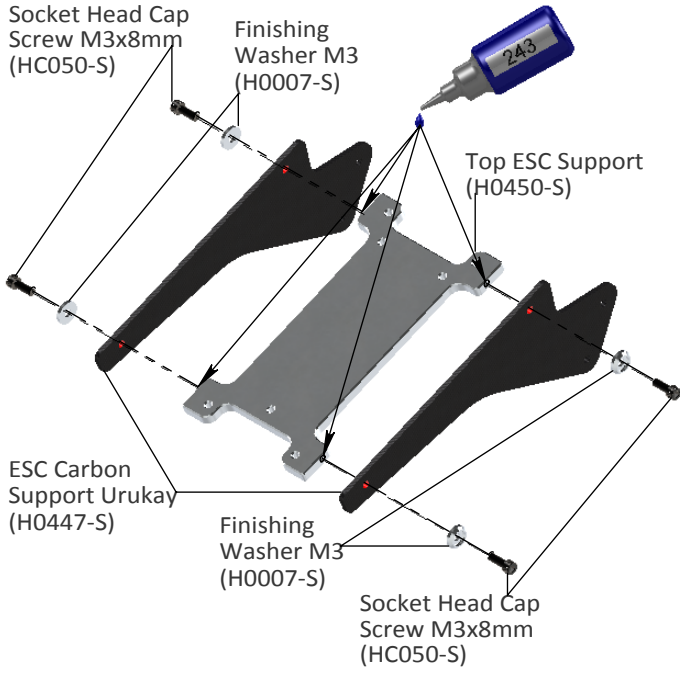

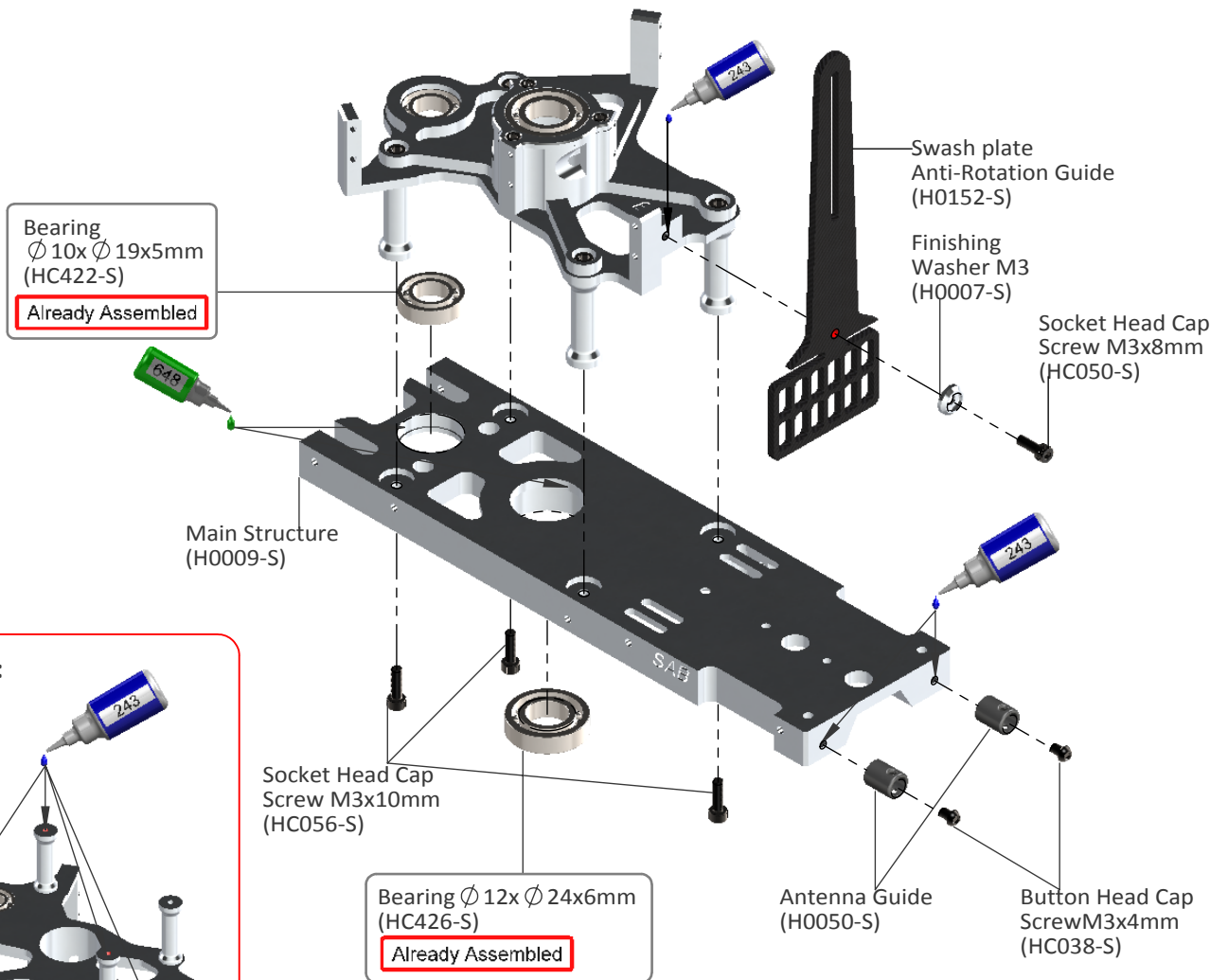
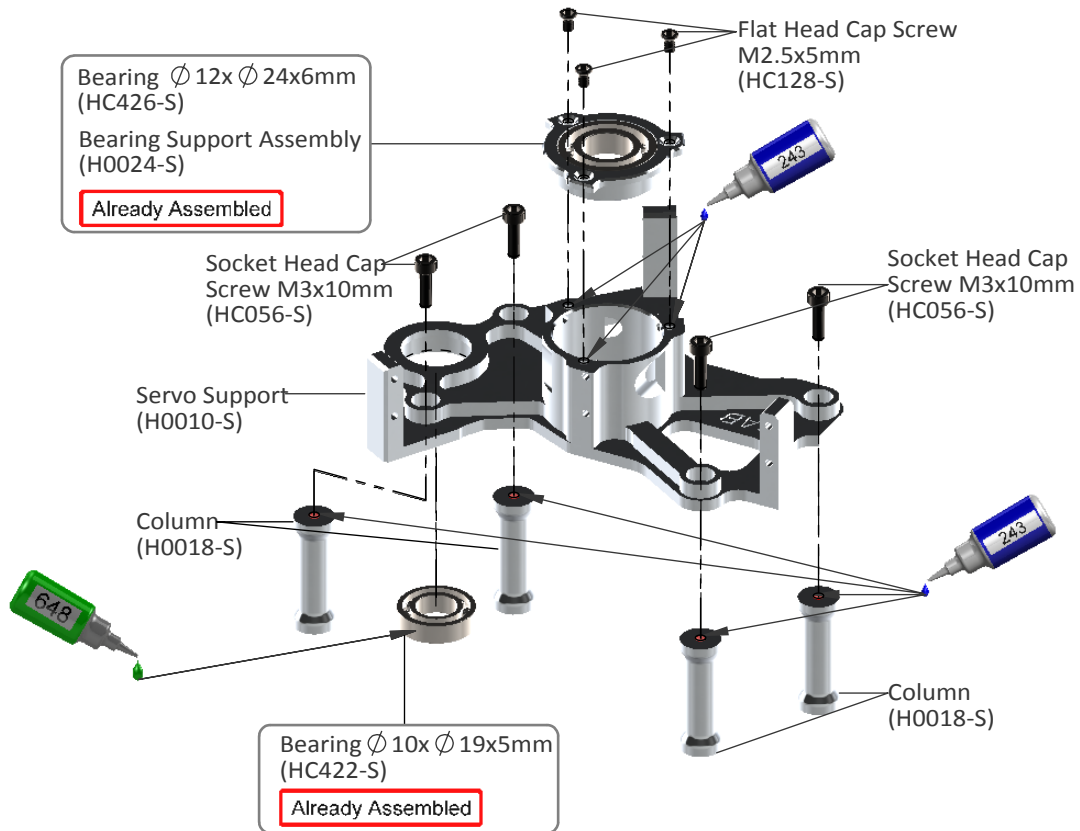

**Note:**

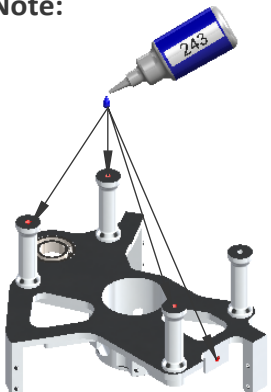



**Note:**

When you tighten the collar (H0121-S) on the main shaft, ensure there is no axial play. Push down the main shaft while pulling up the locking collar. Tighten the screw M4x22 at this time.

**Front Tail Pulley Assembly (H0101-S)**

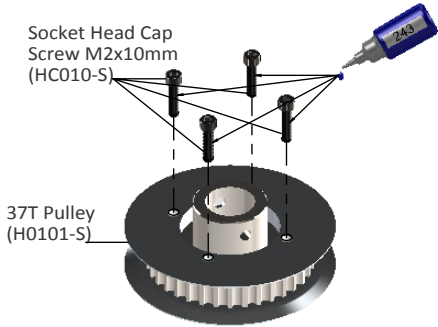

**60T Pulley Assembly (H0104-S)**

Already Assembled

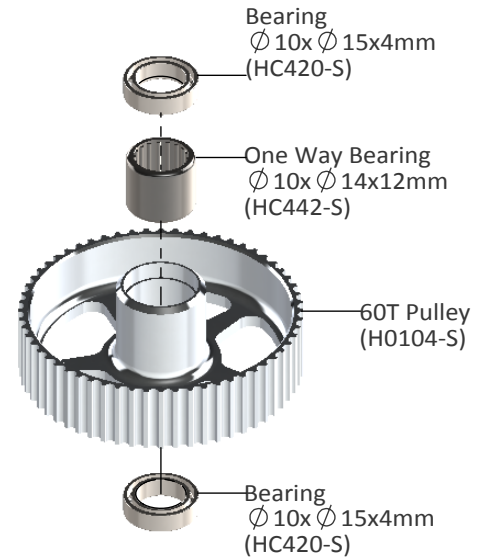

**Main Gear Assembly (H0405-S)**

Already Assembled

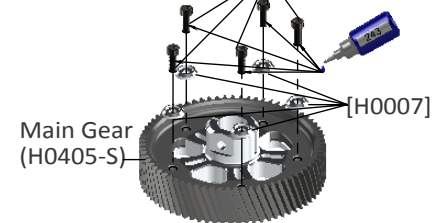

Socket Head Cap Screw Shouldered M3x18mm (HC079-S)

Metric Hex Nylon Nut M3 (HC206-S)

19T Drive Pinion (H0156-S)

Main Gear (H0405-S)

Metric Hex Nut M4 (HC212-S)

Main Structure Assembly 1



Socket Head Cap Screw Shouldered M4x24mm (HC111-S)

Secondary Shaft (H0157-S)

Metric Hex Nylon Nut M4 (HC212-S)

Bush One Way (H0110-S)



M4 Locking Collar (H0121-S)

60T Pulley Assembly (H0104-S)

Use This Hole

Socket Head Cap Screw M4x22mm (HC104-S)

Bush One Way (H0110-S)

Metric Hex Nylon Nut M2.5 (HC200-S)

Washer  $\phi 10 \times \phi 16 \times 0.2 \text{mm}$  (HC232-S)

The perfect play is 0.5mm add or remove shim for this

Socket Head Cap Screw Shouldered M2.5x19mm (HC033-S)

Front Tail Pulley Low Assembly (H0101-S)

**Tail Belt Idler Assembly  
[H0834-S]**

Already Assembled

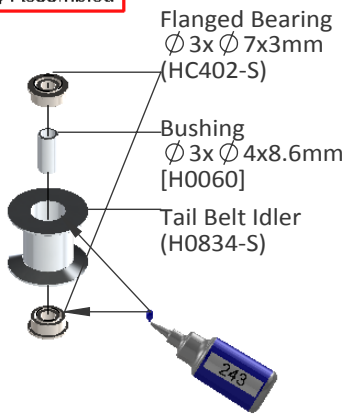

**Belt Tensioner Arm Assembly  
[H0834-S]**

Already Assembled

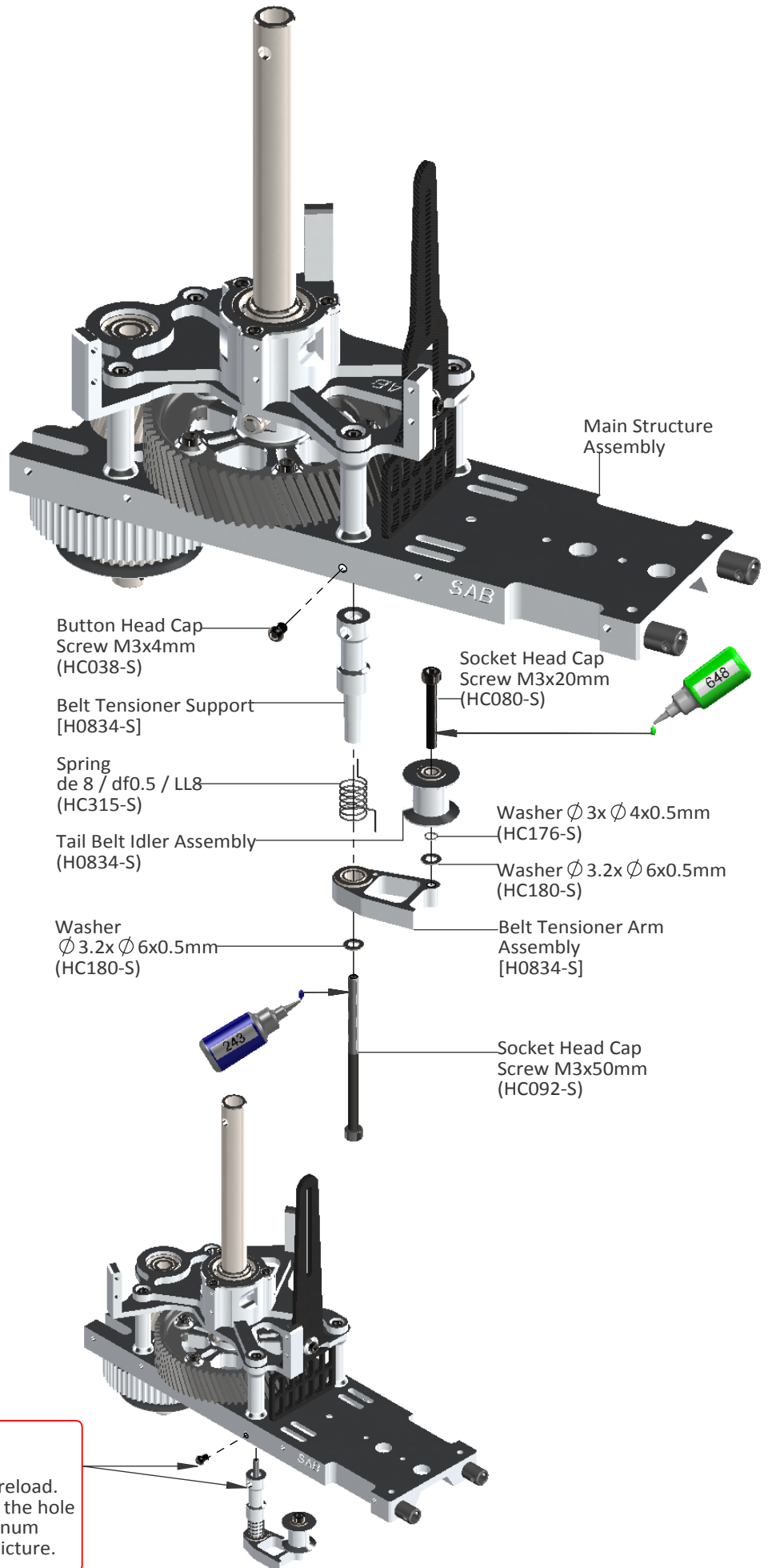
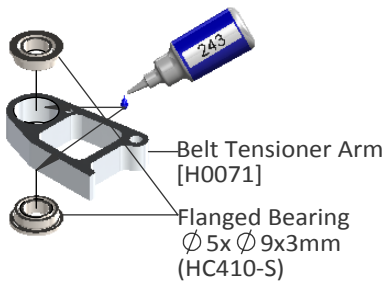

**Note:**

Position without preload.  
Insert the screw in the hole  
through the aluminum  
support as in the picture.

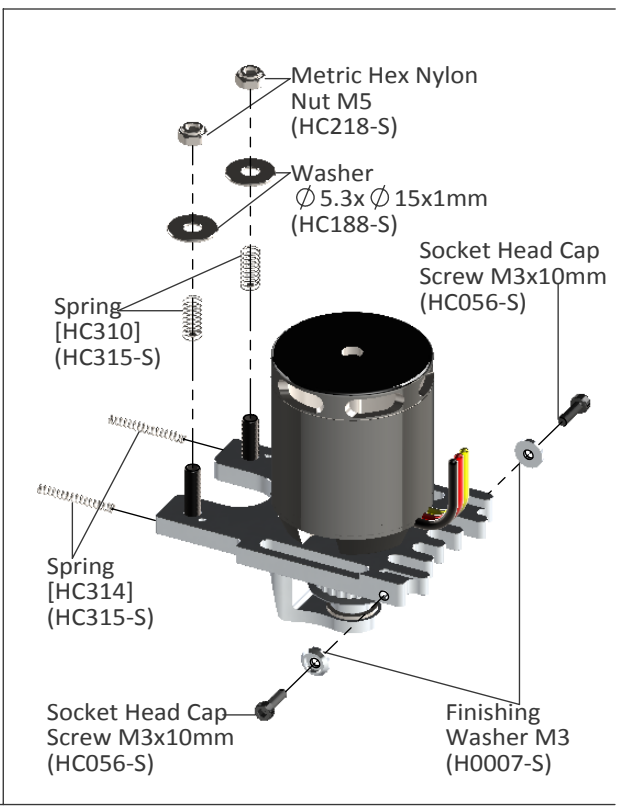
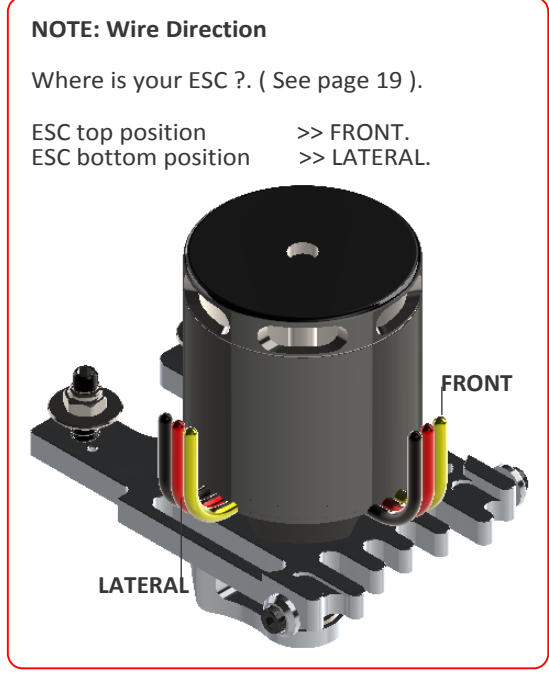
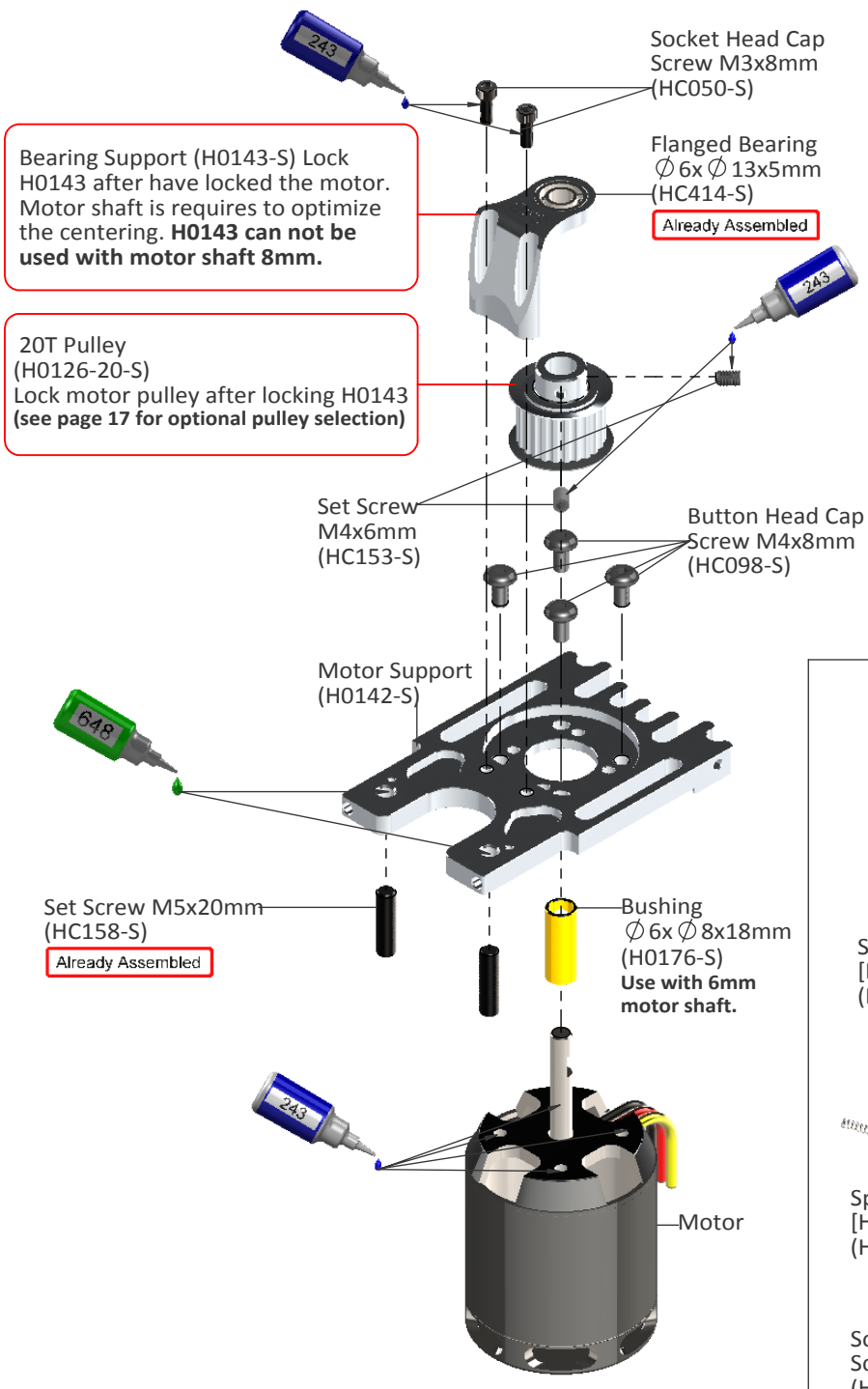

**Note for 6mm Motor Shaft**

To maximize space for the batteries, it is advisable to shorten the motor shaft. Follow the dimensions given in this drawing. For the cut, you can use an electric tool like a "Dremel" with a cut-off disc.

Additionally, ensure the motor shaft has an appropriate 'flat' for one of the set screws.

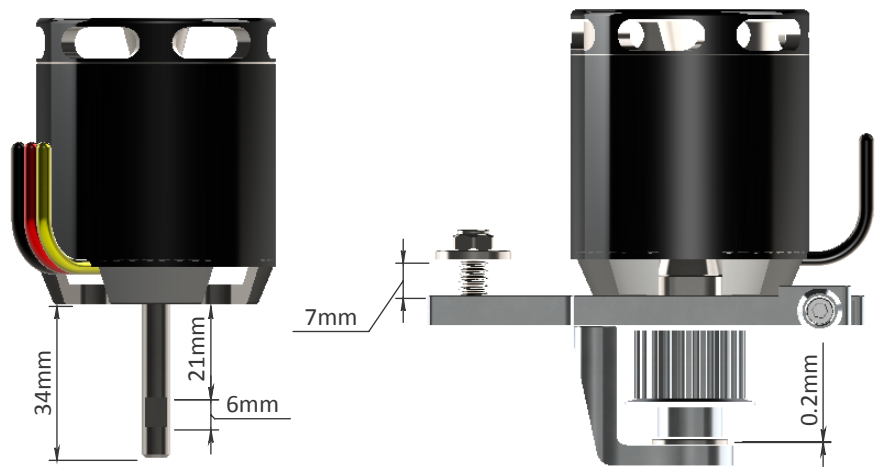



**Uniball Arm Assembly ... x2**

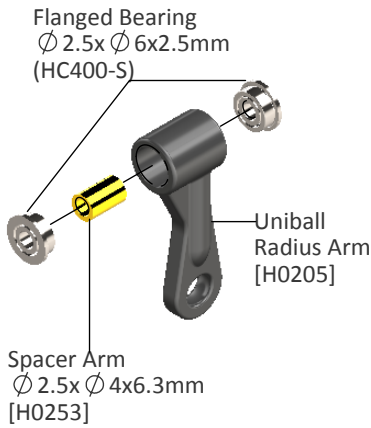

**Radius Arm Assembly ... x2**

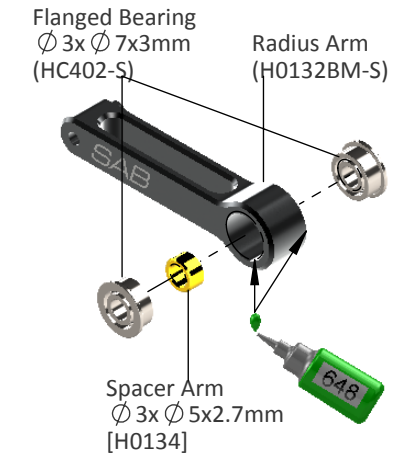

**Center Hub Assembly**

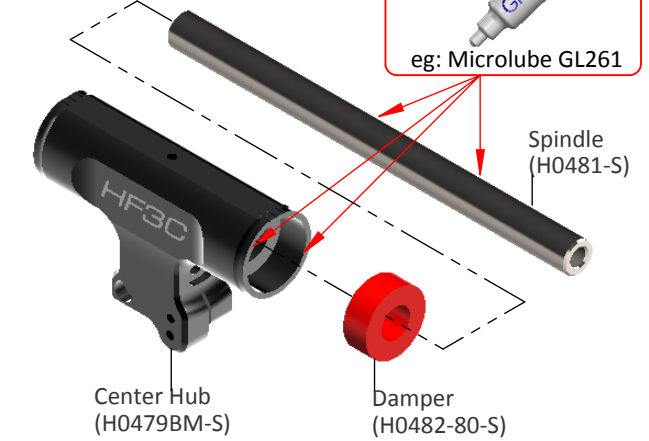

**Note:**

The HF3C head should be assembled with one, 1mm shim (HC230) on each side. The blade grips must move freely, but they should not move just under their own weight. After approximately 10/20 flights, please check preload, you can add one or two 0.2mm shim (HC232) if preload has changed.

**Main Blade Grip Assembly ...x2**

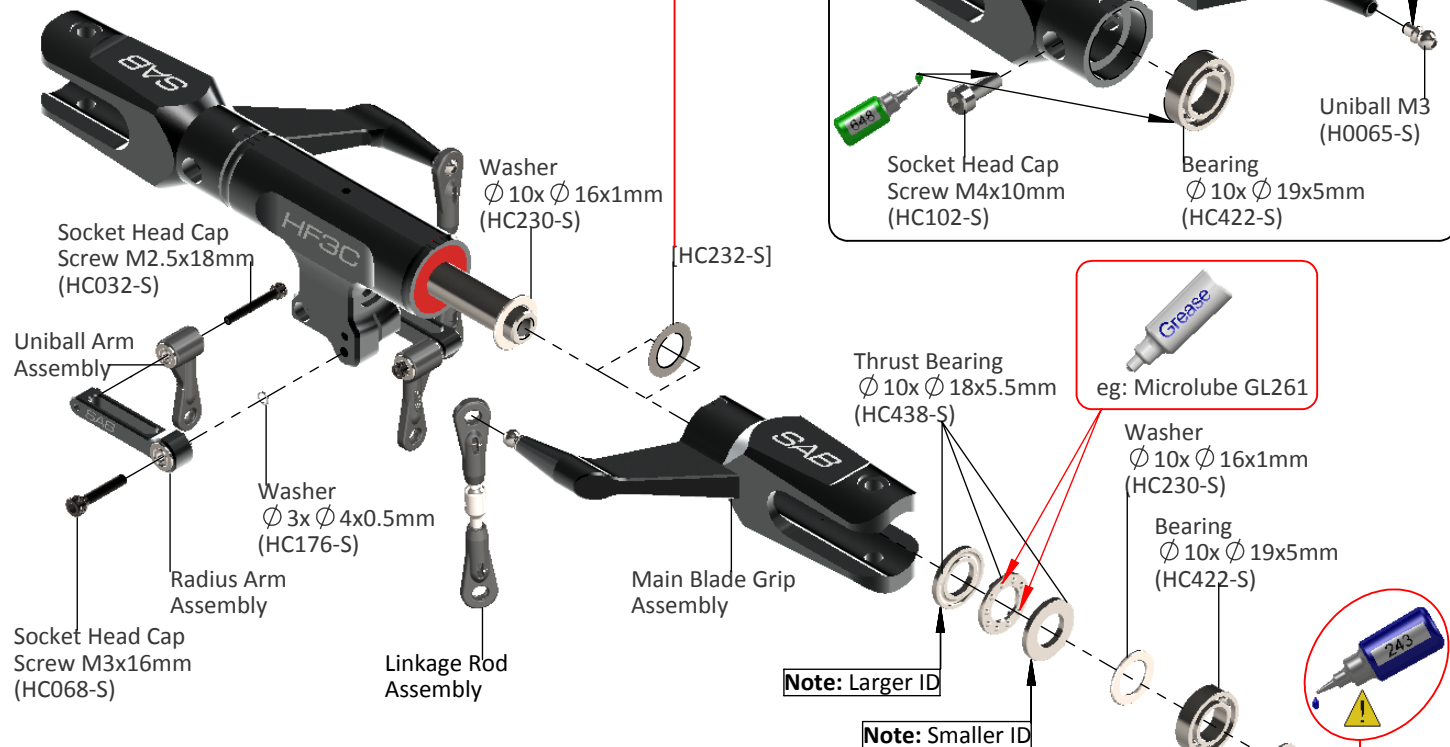

**Linkage Rod A Assembly ...x2**

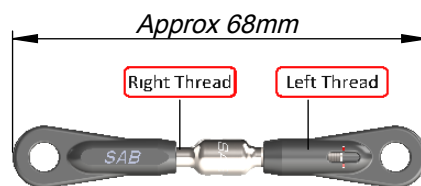
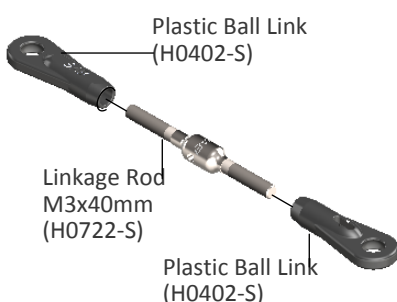

(Initial length for the rods from the swashplate to the Blade Grip.)

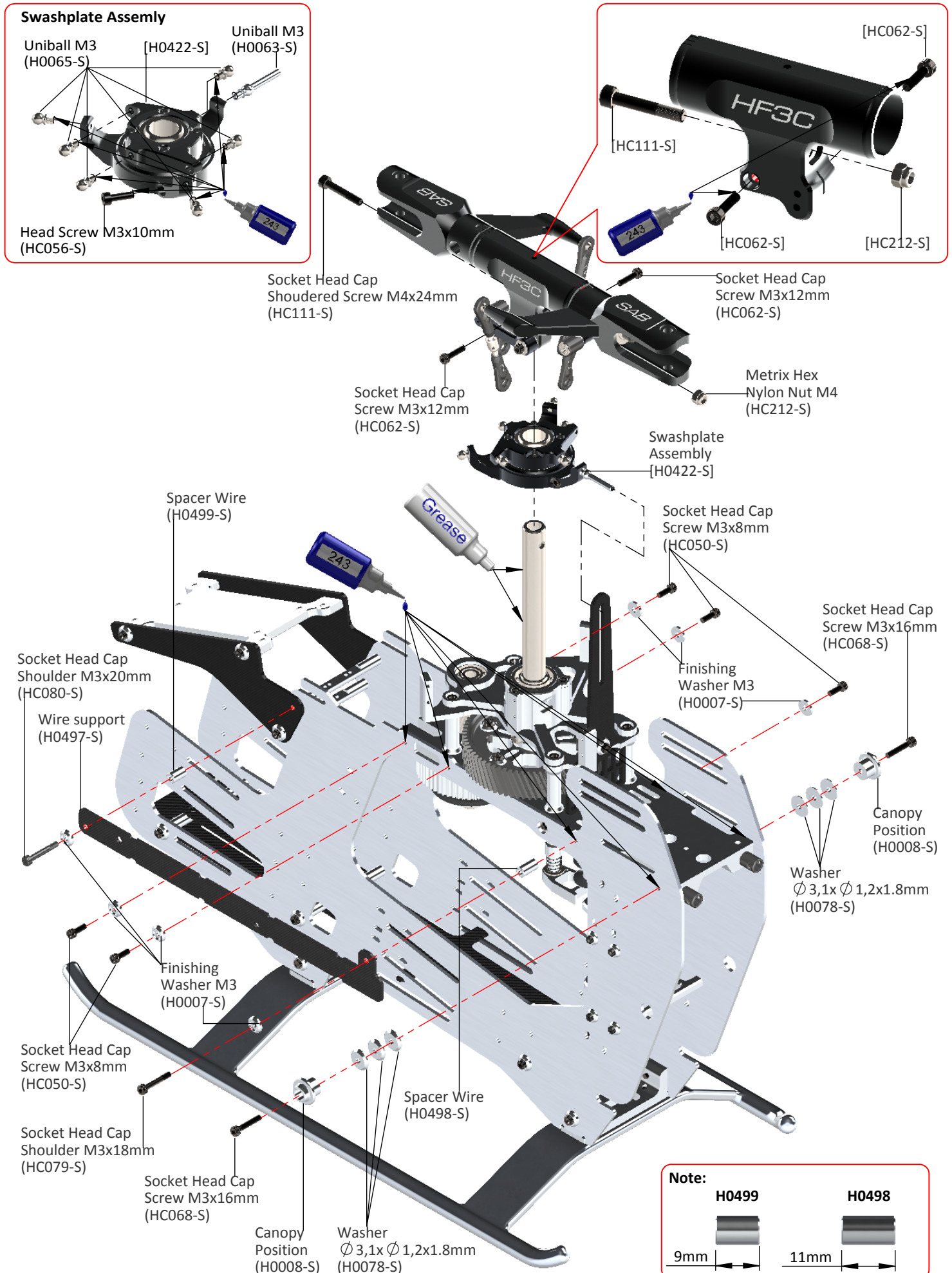

**Note:**

H0499	H0498
9mm	11mm



**INSTALLATION OF SWASHPLATE SERVOS**

The linkage ball must be positioned between 17-19 mm out on the servo arm (Figure 1), recommended servo arm SAB p/n [HA050/HA051]. The 120° placement of the servos inside Goblin means the arms are difficult to access. For this reason it is advisable to ensure alignment of the servo arms (and sub trim set) before installation of the servos in the model. Proceed with installation following the instructions below. Figure 2 shows a completed installation.

Fig. 1

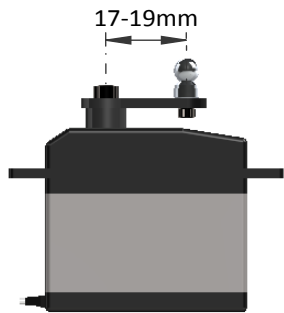
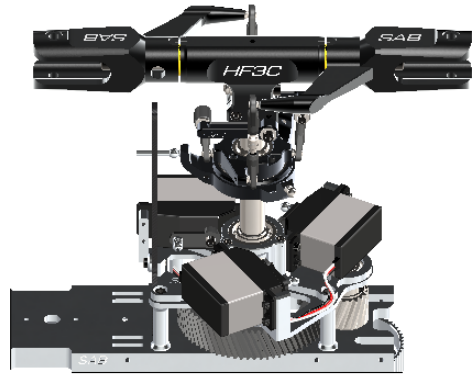

Fig. 2



**ASSEMBLY OF THE BALL ON THE HORN**

The rods going from the servos to the swash plate must be as vertical as possible. Not all servos are equal, so to better align them you can choose to use the supplied spacer H0031. Figure 3 illustrates this.

Fig. 3

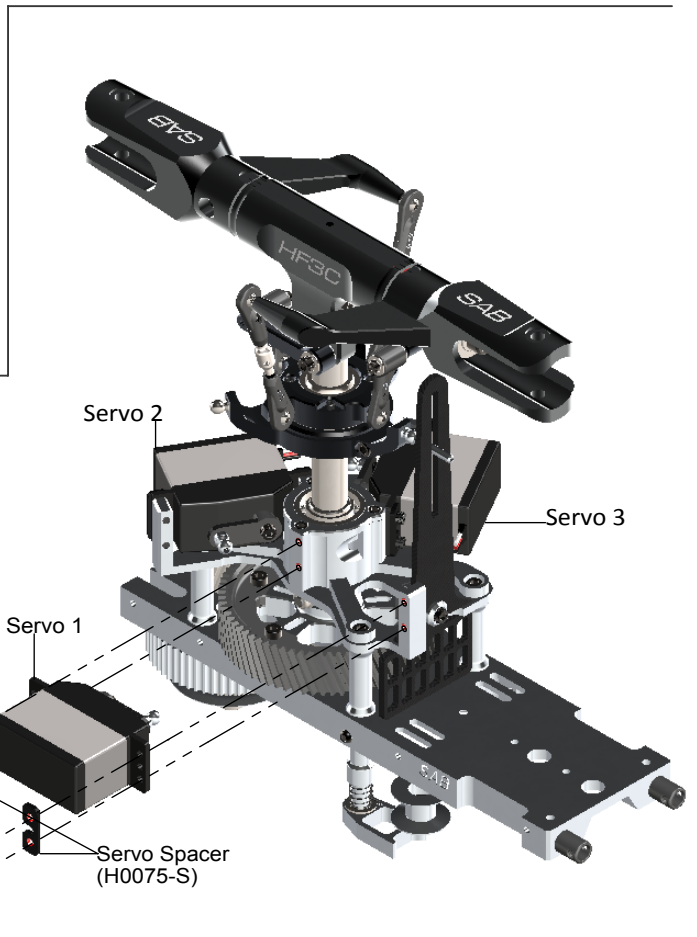
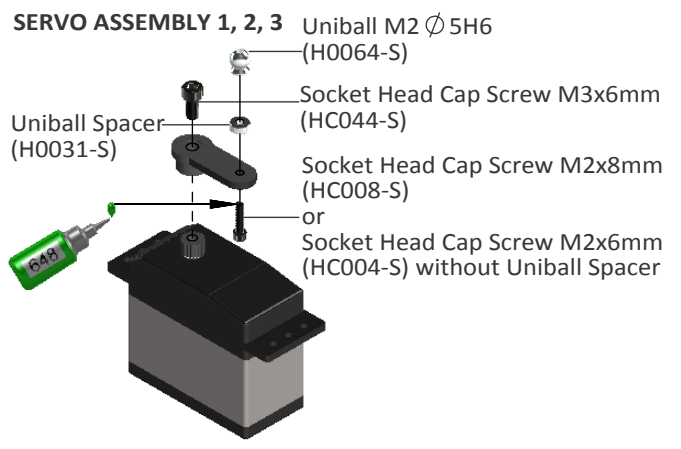
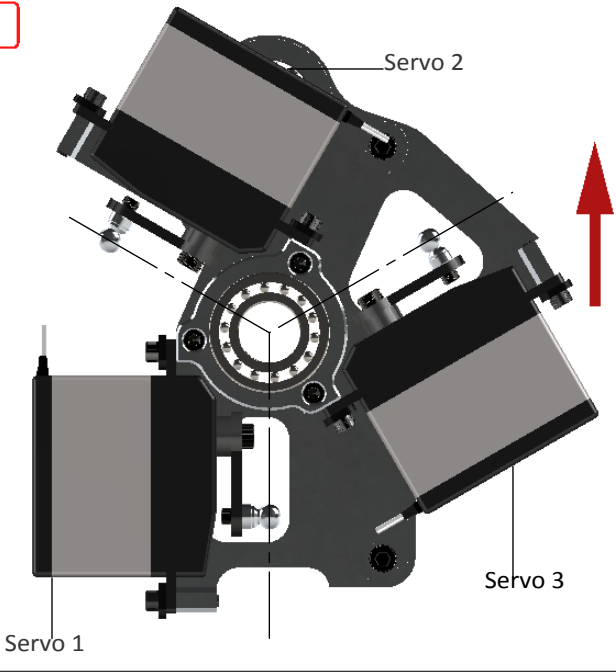

The wire for the front servo must be positioned here. Use zip ties.

Fig. 5

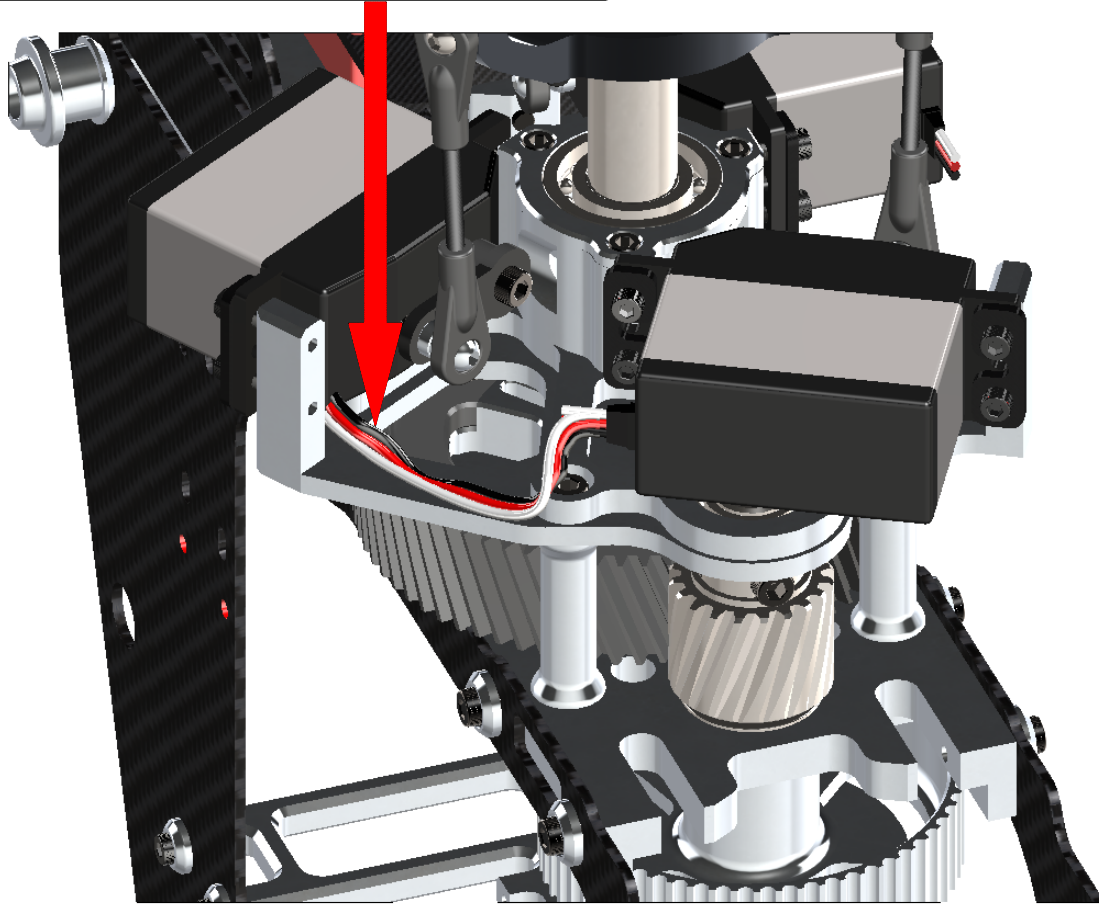

### Head HF3C Version Preliminary Setup

Adjust the linkage as shown. The linkage Rod A has thread right/left. Turning, you can change the tracking without disconnecting the plastic ball link.

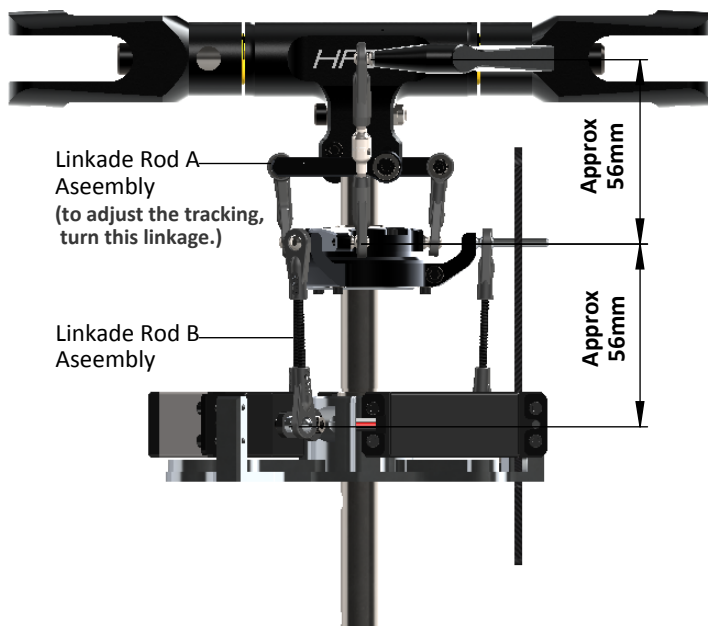

### Linkage Rod A Assembly ... x2

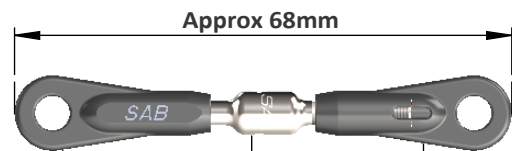

Plastic ball link (H0402-S)      Linkage Rod M3x40mm (H0722-S)      Plastic ball link (H0402-S)

Initial length for the rods from the swashplate to the blade grips.

### Linkage Rod B Assembly ... x3

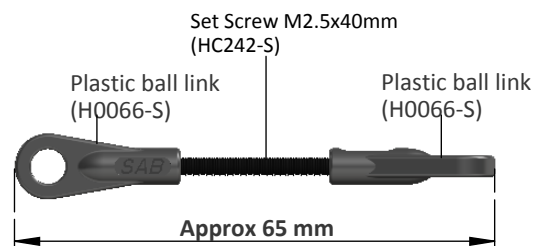

Set Screw M2.5x40mm (HC242-S)

Plastic ball link (H0066-S)

Plastic ball link (H0066-S)

Approx 65 mm

Initial length for the rods from the servos to the swash plate.

## TRANSMISSION SETUP

It is important to choose the right reduction ratio to maximize efficiency based on your required flight performance. The Goblin has many possible reduction ratios at your disposal. It is possible to optimize any motor and battery combination. It is recommended to use wiring and connectors appropriate for the currents generated in a helicopter of this class.

If you are using a head speed calculator which requires a main gear and pinion tooth count, use **214** teeth for the main gear (this takes into account the two stage reduction) and the tooth count of your pulley as the pinion count.

**Below is a list of available reduction ratios:**

H0126-18-S - 18T	Pinion = ratio	11.9:1	H0126-22-S - 22T	Pinion = ratio	9.8:1
H0126-19-S - 19T	Pinion = ratio	11.3:1	H0126-23-S - 23T	Pinion = ratio	9.3:1
H0126-20-S - 20T	Pinion = ratio	10.7:1	H0126-24-S - 24T	Pinion = ratio	8.9:1
H0126-21-S - 21T	Pinion = ratio	10.2:1	H0126-25-S - 25T	Pinion = ratio	8.6:1

**NOTE: If your motor has 6mm motor shaft, you can use the series H0015-xx-S**

Some example configurations:

Battery	Motor	ESC	Pinion	RPM Max	Pitch
					REV 01
12S 5000/5500 mAh	Kontronik Pyro 800-480	Edge 160 HV	21T - 22T	1800 rpm 1900 rpm	± 12,5
		HobbyWing 160/200 KOSMIK 160/200	20T - 21T		
	Xnova 4530-500KV Quantum 4530 - 500	Edge 160 HV	20T - 21T		
		HobbyWing 160/200 KOSMIK 160/200	19T - 20T		
	Scorpion HK-4526-520KV F3C Edition	Edge 160 HV	19T - 20T		
		HobbyWing 160/200 KOSMIK 160/200	18T - 19T		
KDE Direct 700XF - 535 - G3					

**Note: For safety reasons we suggest to not exceed 2000 rpm.**

## INSTALLATION TAIL SERVO

The distance between the axis and the ball must be between 15-16 mm

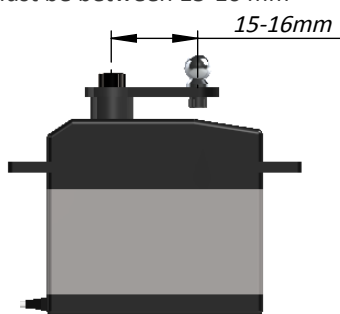

### Tail Servo Assembly

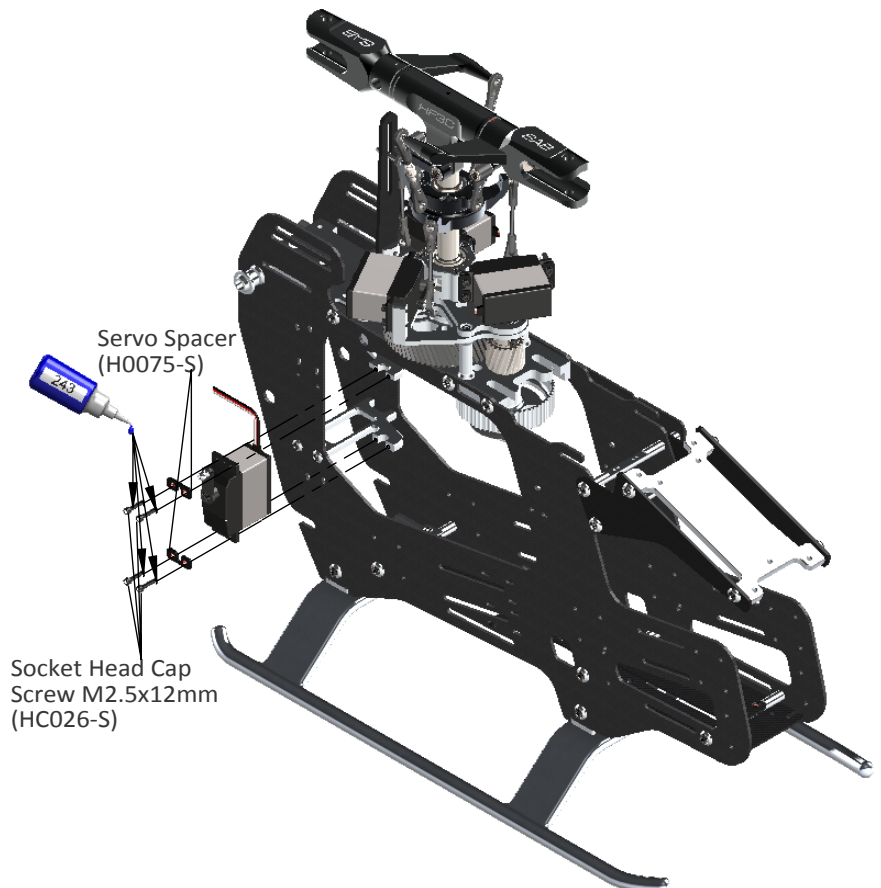
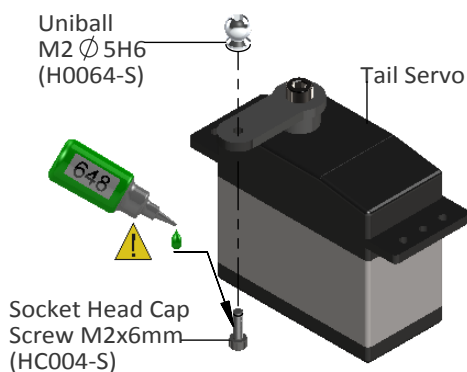

## MOTOR BELT TENSION

- \*Assemble the motor and pinion to its mounting plate.
- \*Fit the motor assembly into position.
- \*Compress the springs by pushing the motor toward the main shaft.
- \*At maximum compression, temporarily tighten one of the slide screws.
- \*With the minimum centre distance it is easy to install the belt. First put the belt on the motor pinion.
- \*Then put the belt around the big pulley.
- \*Rotate the motor several times by hand.
- \*Release the screw that locks the slide.
- \*The springs keep the belt in tension.
- \*Help the springs by pulling the motor slightly.
- \***The belt must be very tight.**
- \*Lock all screws.

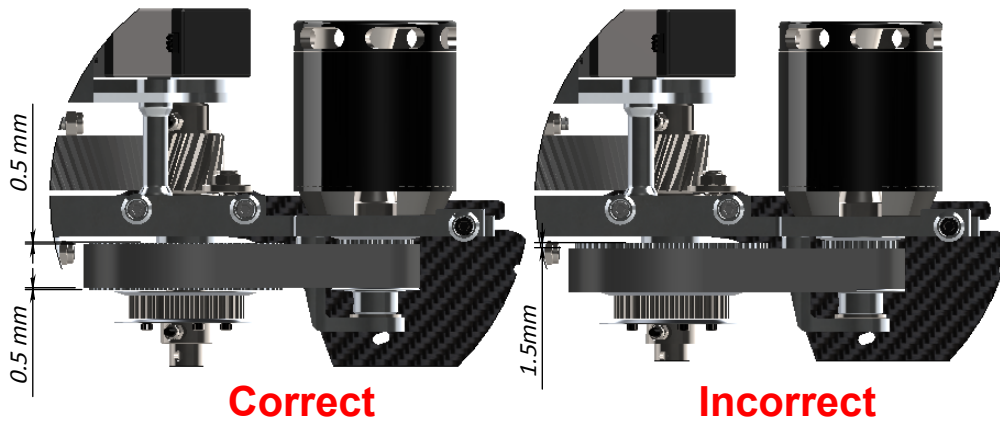

### Note:

Check for vertical alignment of the motor pulley. To do this, simply turn the motor several times and check to see if the belt is aligned with the big pulley (one way bearing pulley). If the belt is riding too high, simply loosen up the motor pulley and drop it just a little bit, if it is riding too low, loosen up the motor pulley and raise it a bit.

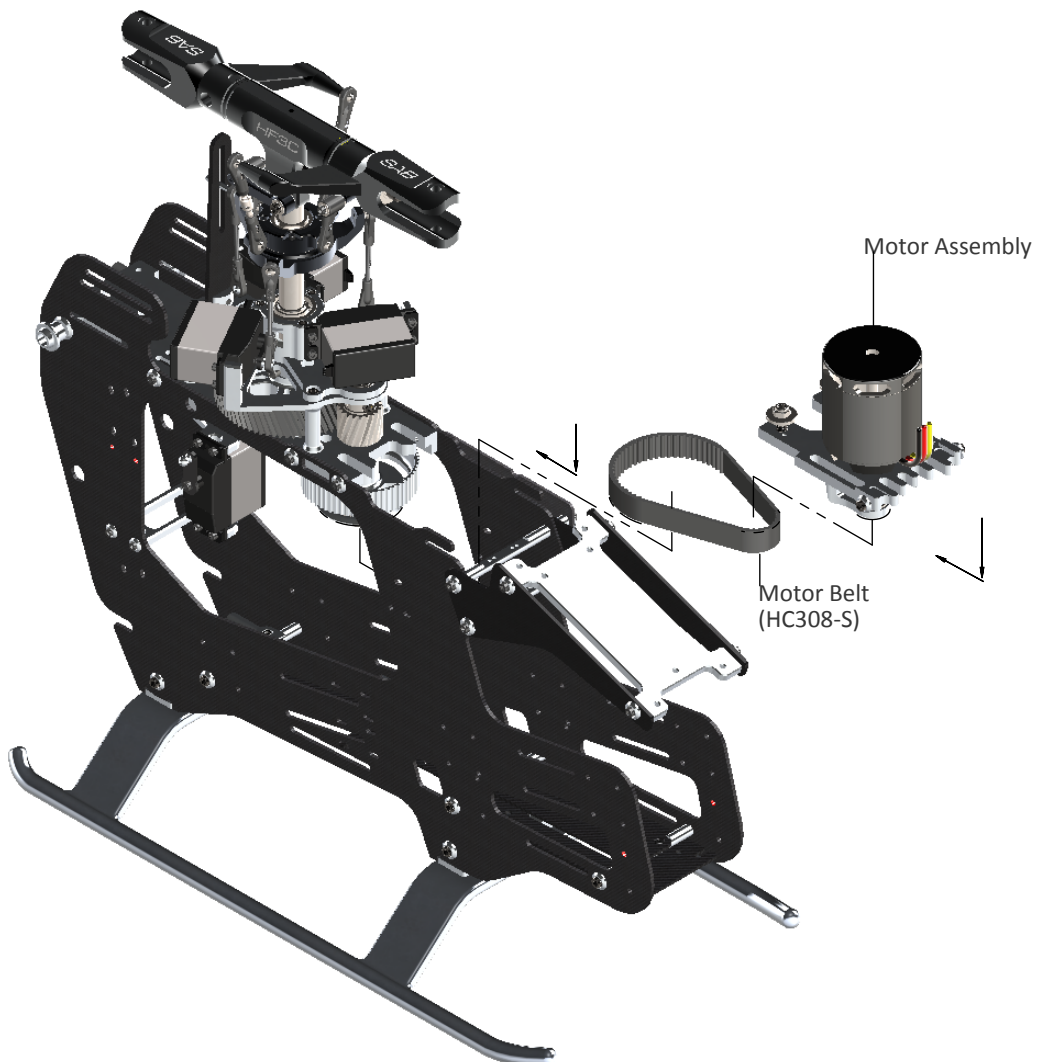

**DE-BURR THE SIDE FRAMES**

We recommend de-burring the edges of the carbon parts in areas where electrical wires run. ( See page 4)



**ESC INSTALLATION**

**Figure 1:** shows the installation of the Kosmik ESC from Kontronik.

**Figure 2:** Shows the wiring which connects the receiver and ESC. If the BEC used is combined with the ESC, it is recommended to use a dual wire connection and a unit battery backup.

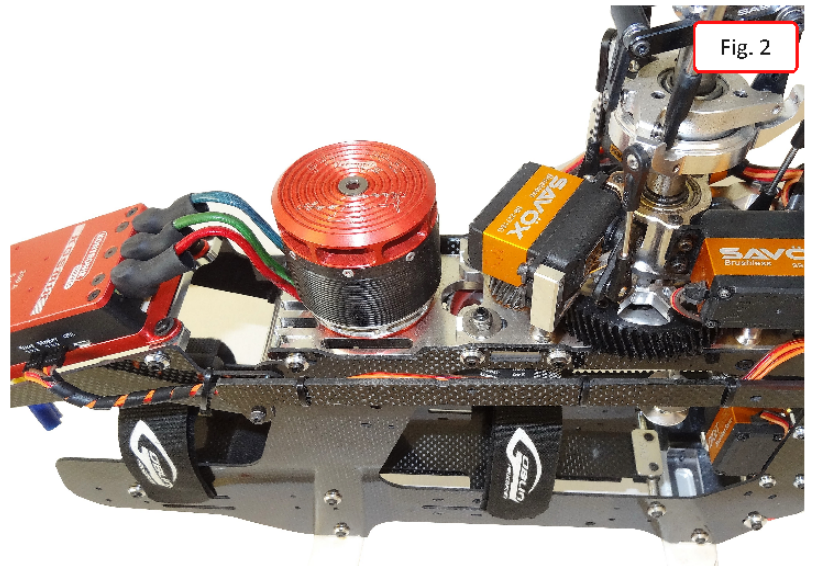
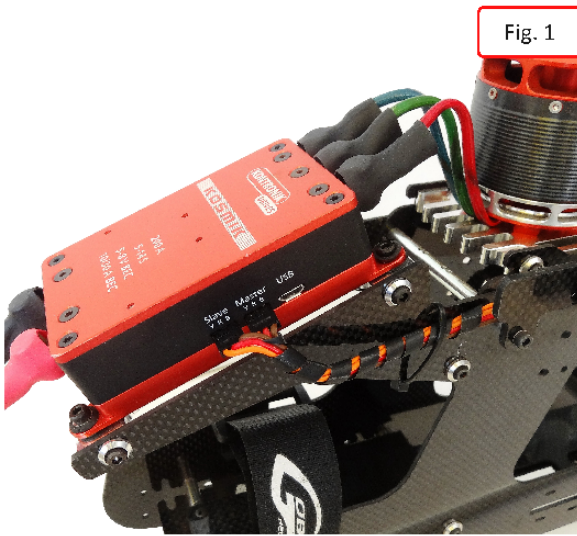

**Different options for installing the ESC:**

These picture show the ESC installed in the bottom section. The many positions allow you to find the best personal setup for CG and battery setup. Important, use zip tie to lock the ESC wire to the frame.

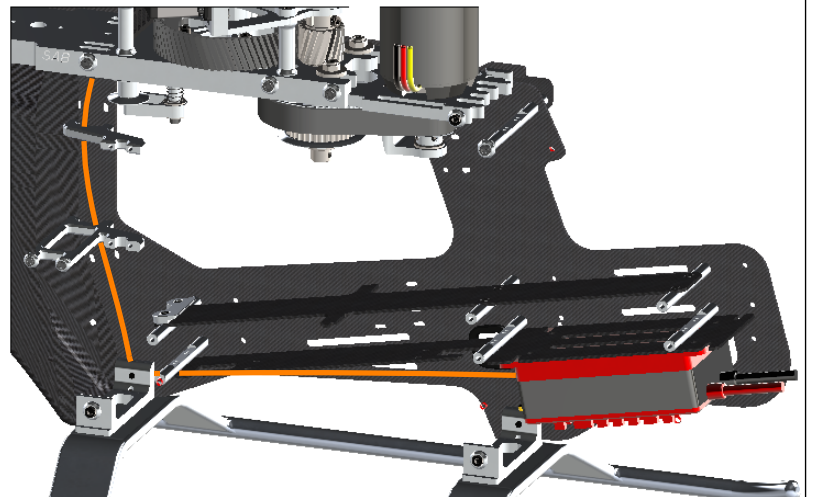
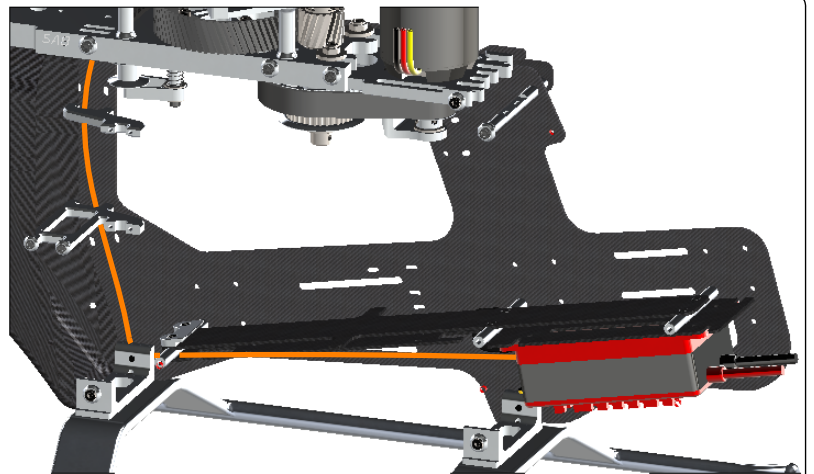

FLYBARLESS CONTROL UNIT AND RX INSTALLATION

Figures 1 shows an example of installation of the flybarless control unit.

You can use short spacer H0727 ( Figure 2 ).

You can use long spacer H0043 ( Figure 3 ). This is typical if you want to put RX satellite under the control unit.

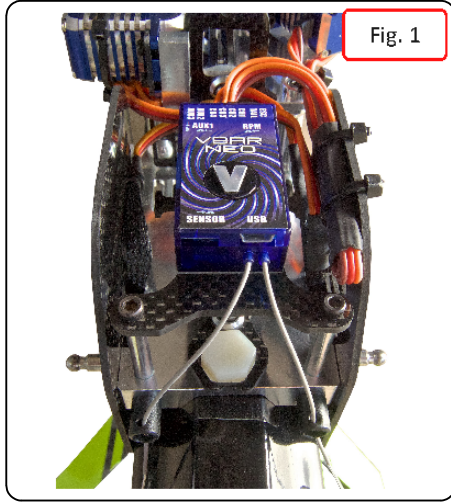

Fig. 1

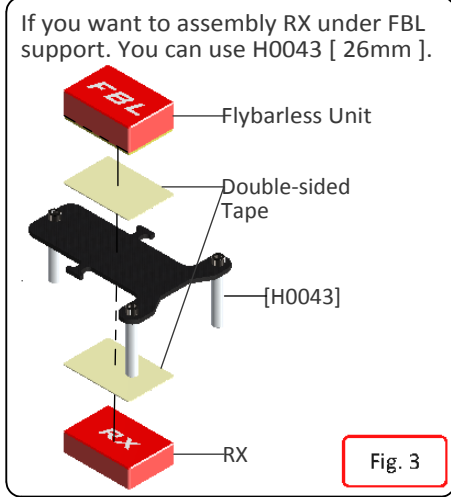

Fig. 3

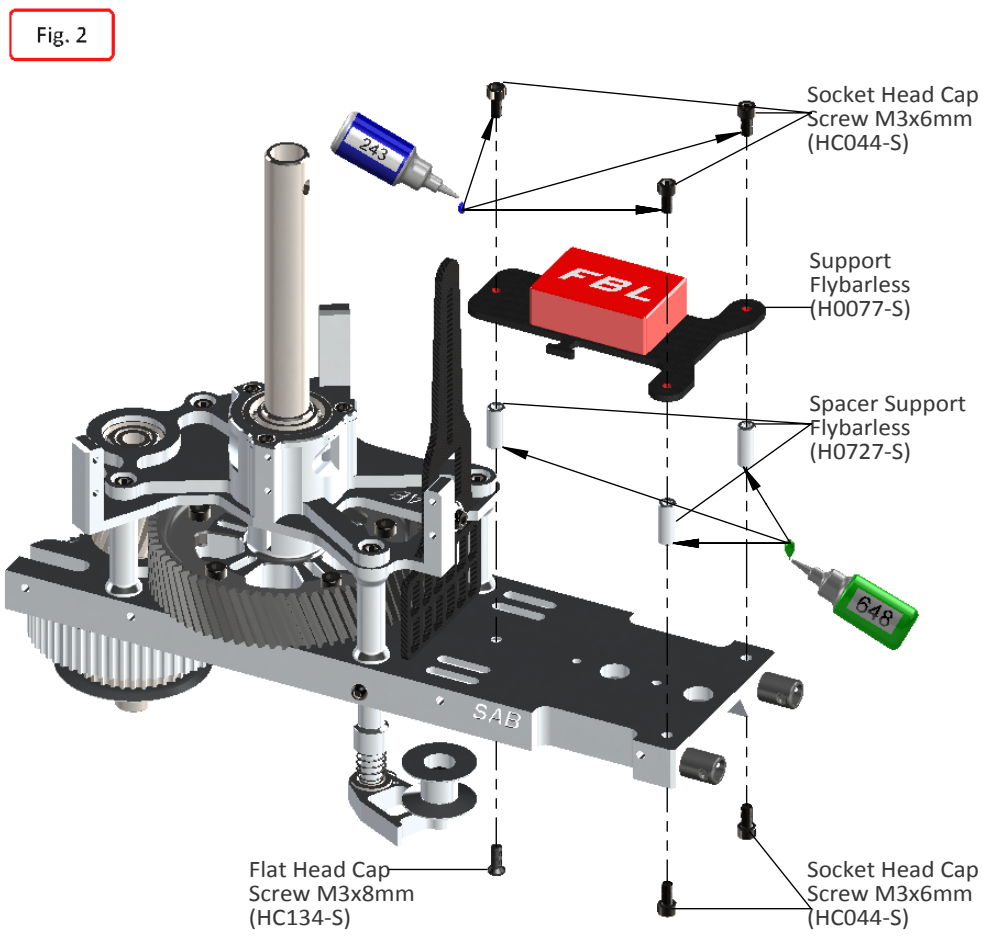
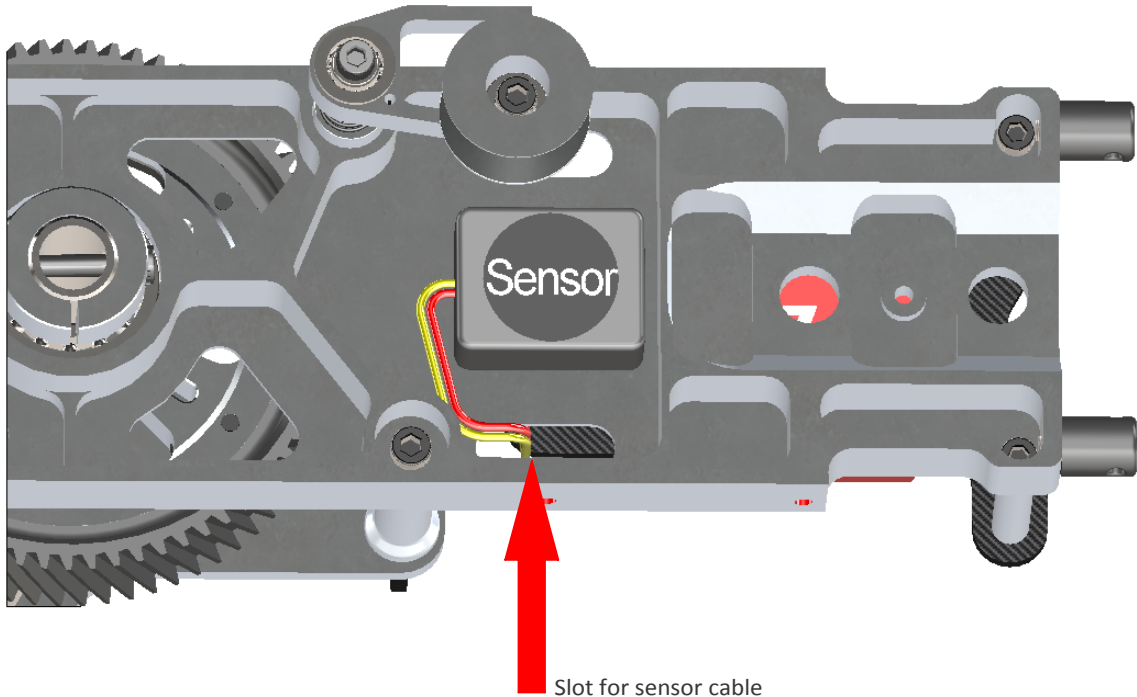

Fig. 2

For Flybarless systems with a separate sensor, the sensor must be installed under the main plate (Figure 4).

Fig. 4



### Tail Rotor Hub Assembly

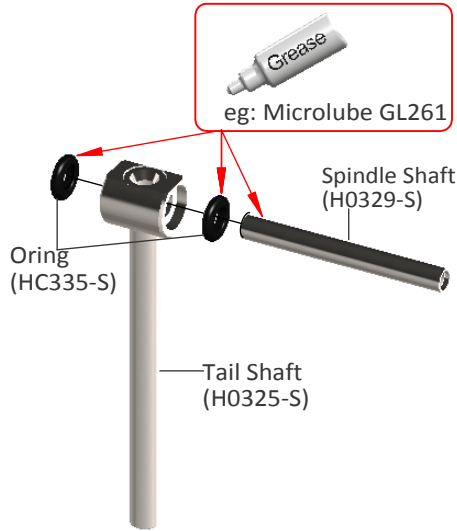

### Tail Pitch Slider Assembly

Already Assembled

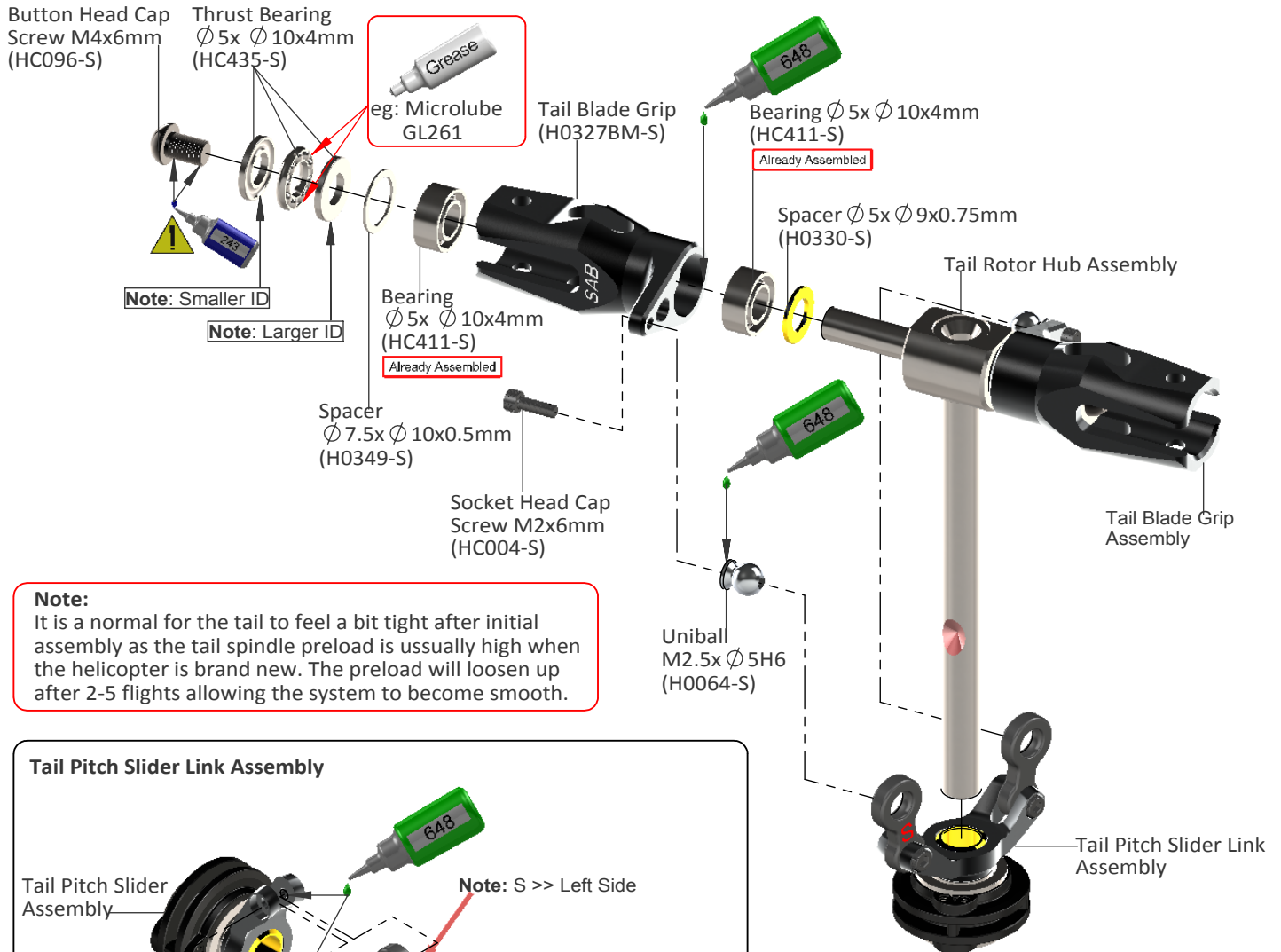
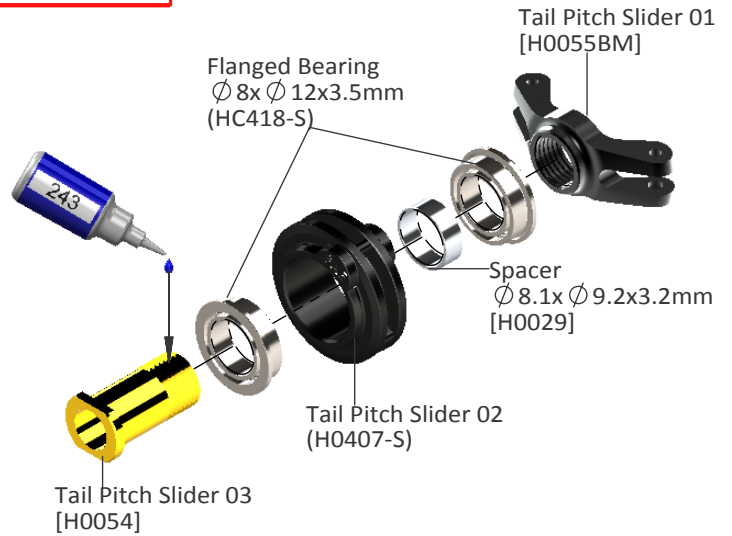

**Note:**  
It is normal for the tail to feel a bit tight after initial assembly as the tail spindle preload is usually high when the helicopter is brand new. The preload will loosen up after 2-5 flights allowing the system to become smooth.

### Tail Pitch Slider Link Assembly

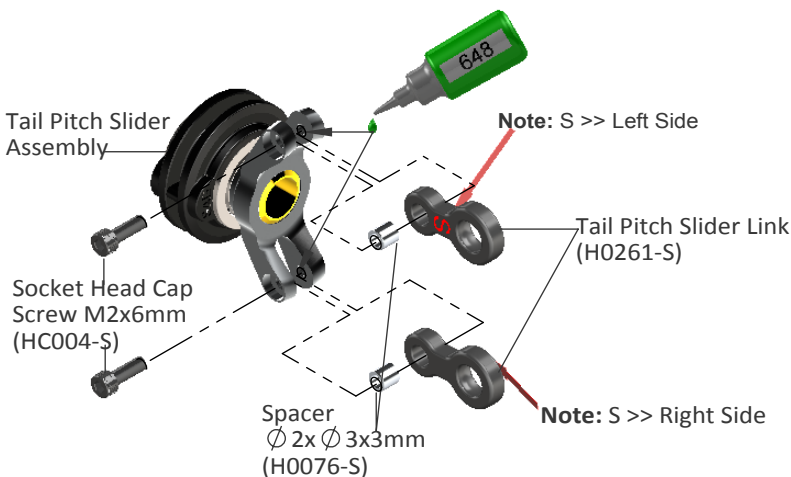



**Bell Crank Lever Assembly**

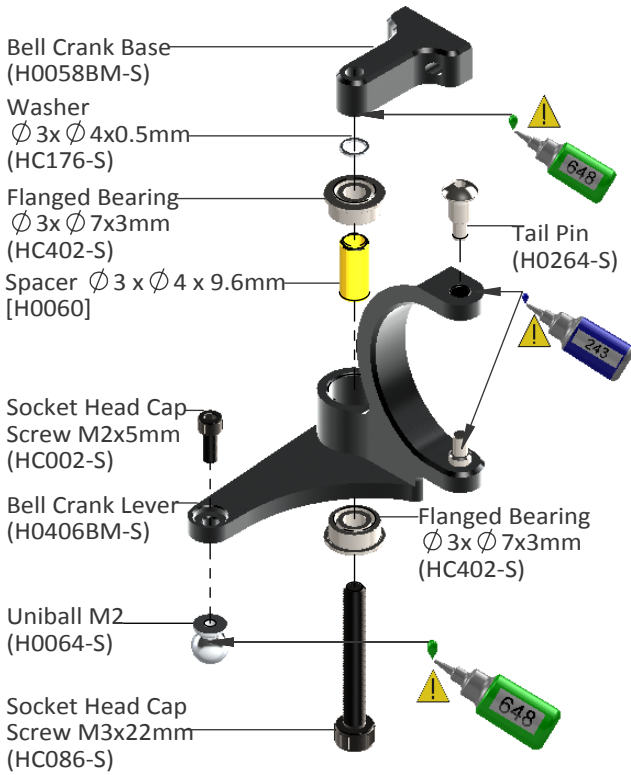

**Tail Side Plate Assembly**

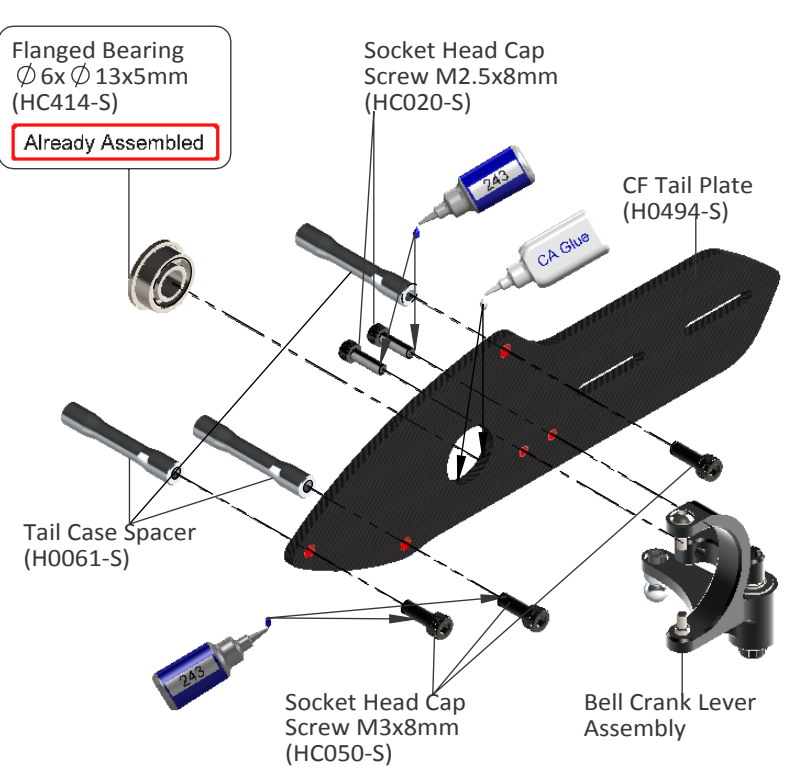

**Tail System Assembly**

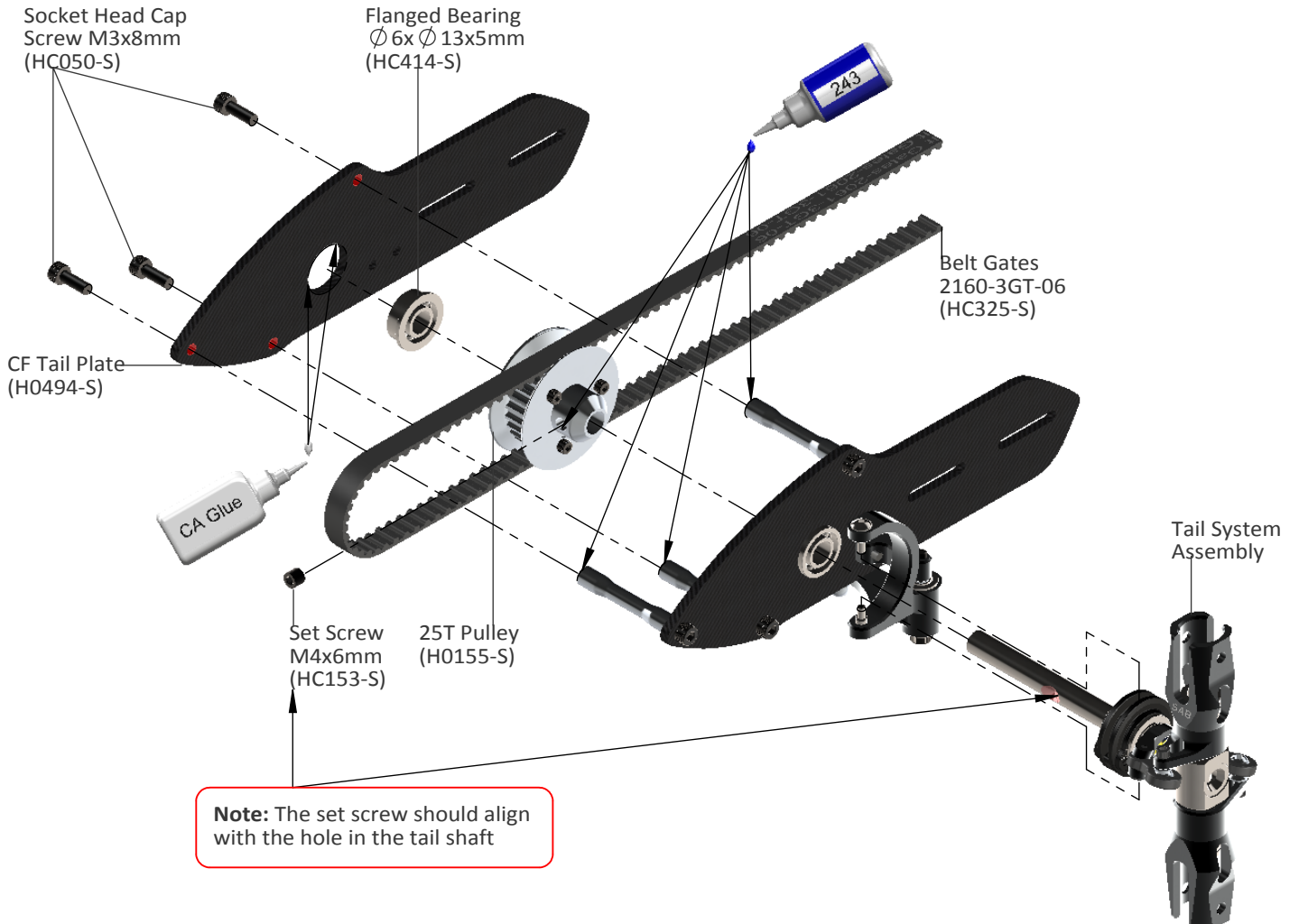





### Tail Boom Assembly

Red Tail Fin (H0823-S)

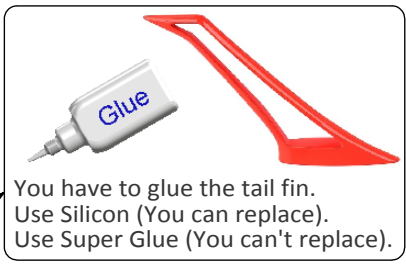

Carbon Fiber Tail Boom Silver/Carbon (H0724-S)  
Carbon Fiber Tail Boom Ennio Graber Edition (H0822-S)

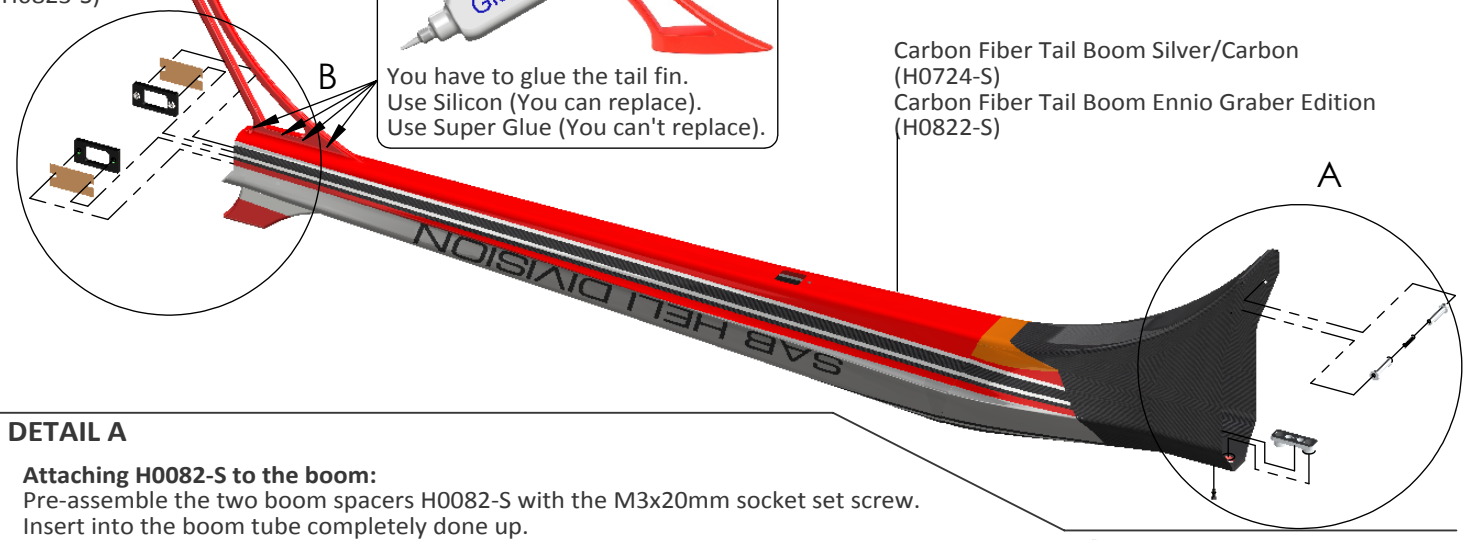

### DETAIL A

#### Attaching H0082-S to the boom:

Pre-assemble the two boom spacers H0082-S with the M3x20mm socket set screw. Insert into the boom tube completely done up. Center the holes, then unscrew until there is contact with the walls. Lock everything with the adhesive.

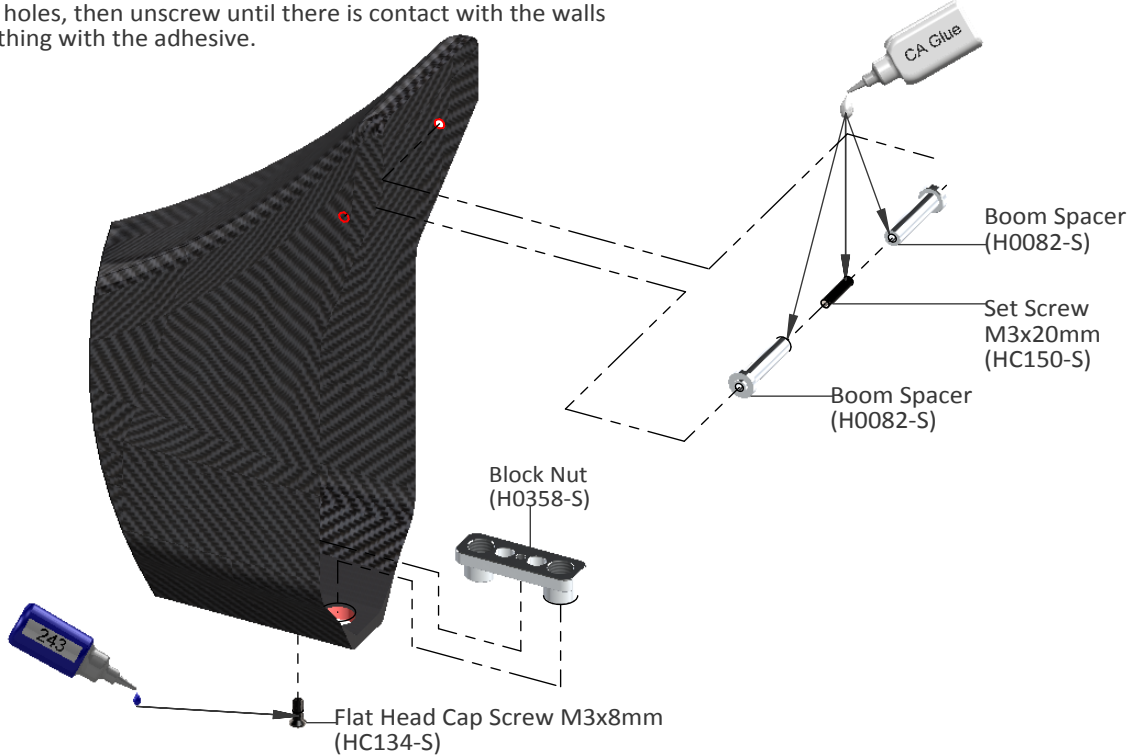

### DETAIL B

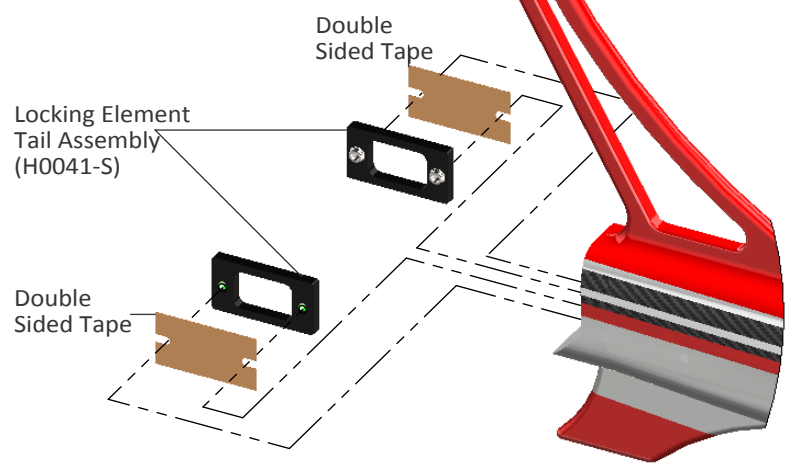

### Locking Element Tail Assembly .... X 2

Already Assembled

Locking Element Tail (H0041-S)  
Metric Hex Nylon Nut M3 (HC206-S)

Note:

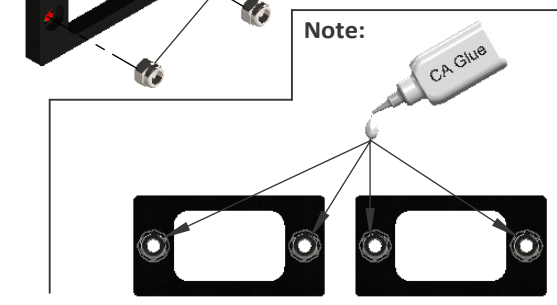

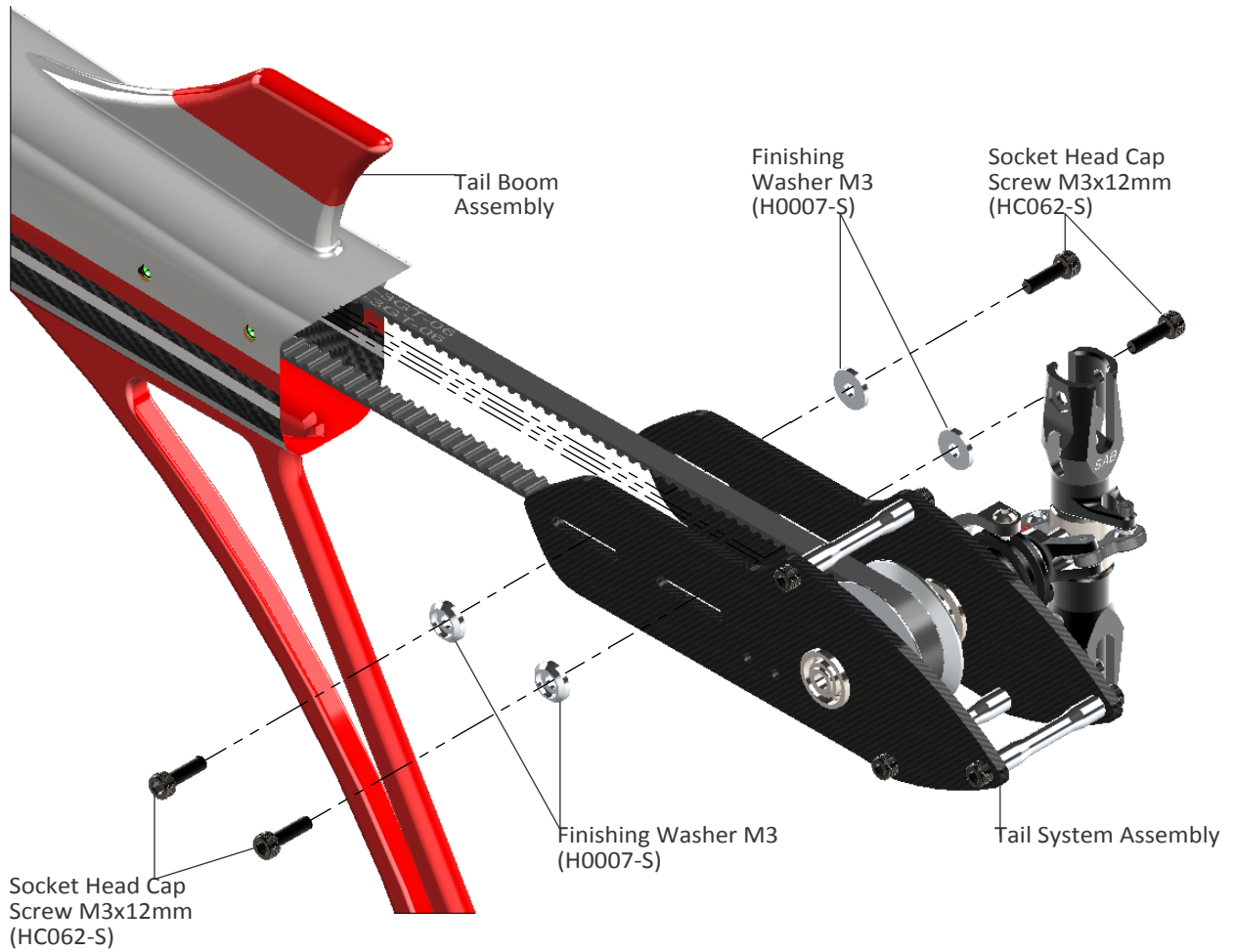

**Note:** Before put plastic ball in threaded rod, please wait 12 hours after bonding

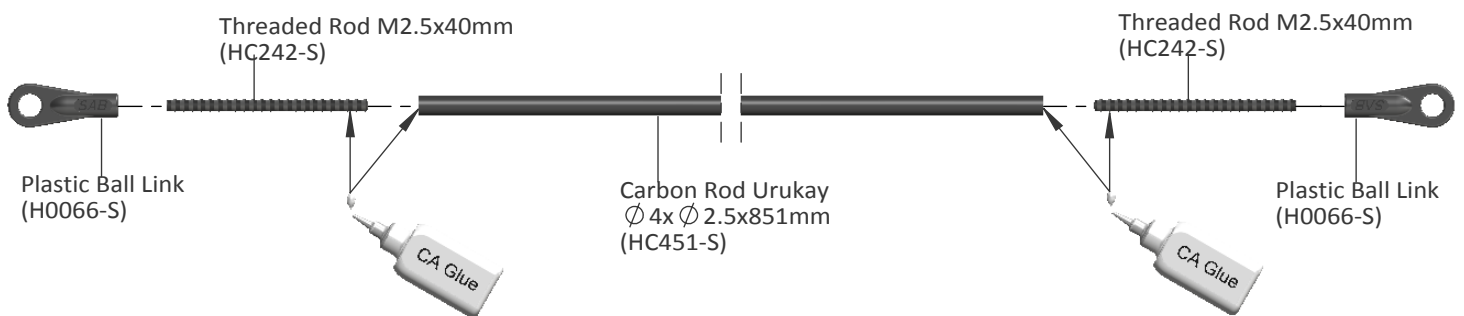

**Note:**

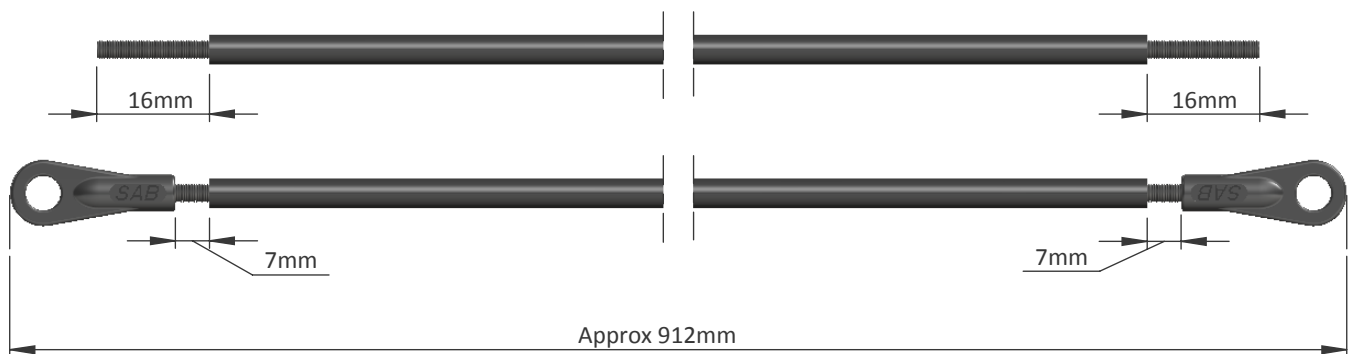

**Note:**

- \* Install H0394 to the boom.
- \* Insert carbon rod through the boom making sure it is inserted through H0394.
- \* Install H0395 making sure to reduce slop (side play) on the carbon rod.

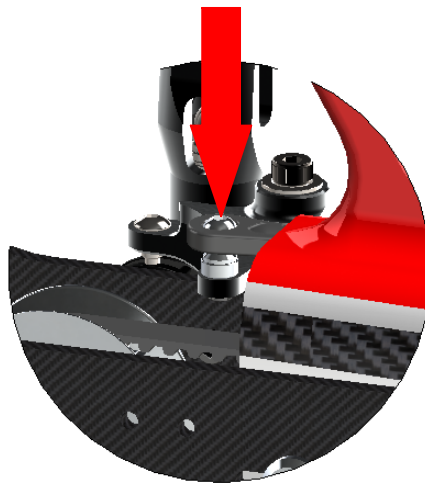
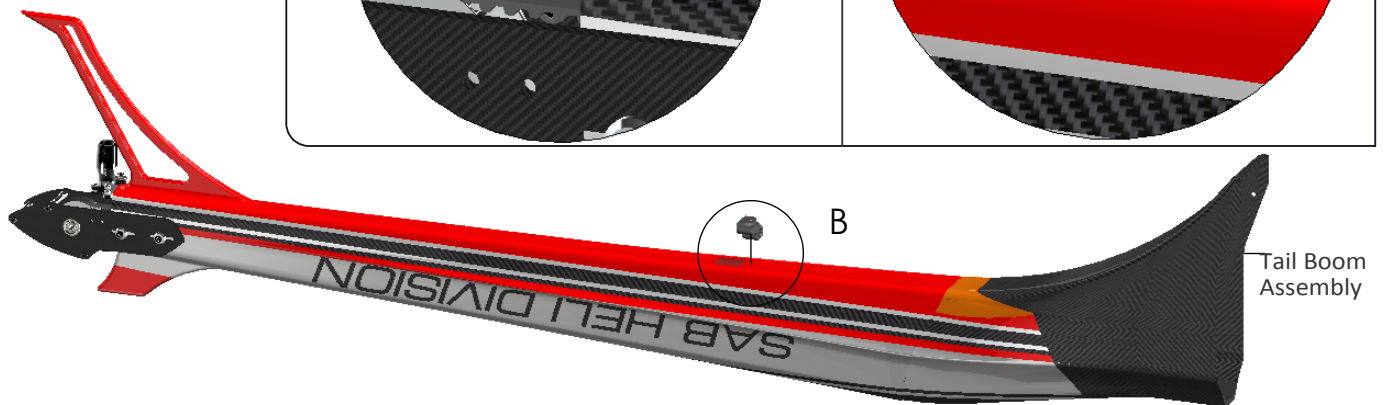
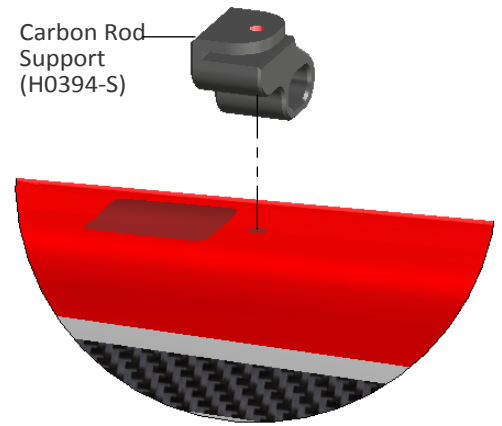
**DETAIL A****DETAIL B**

Tail Boom Assembly

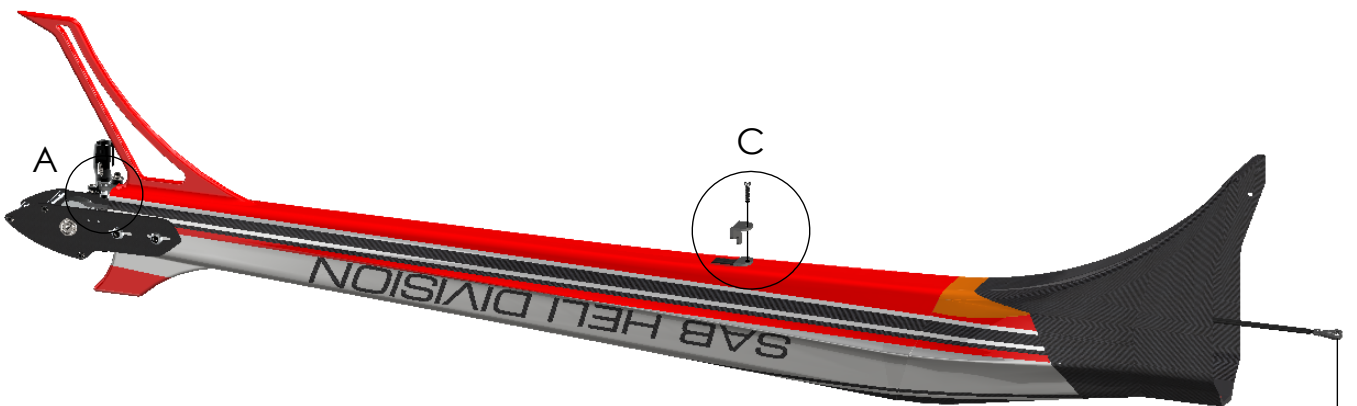

Carbon Rod Assembly (HC451-S)

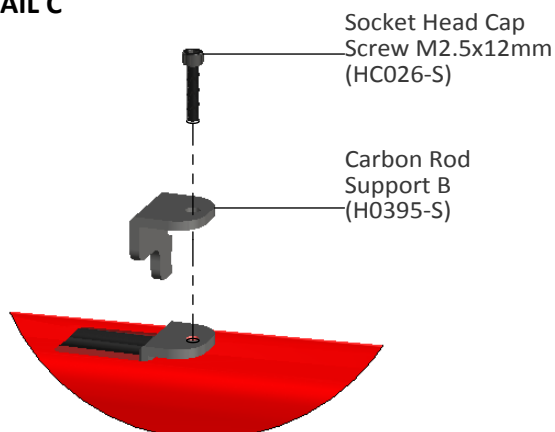
**DETAIL C**

Socket Head Cap  
Screw M2.5x12mm  
(HC026-S)

Carbon Rod  
Support B  
(H0395-S)

**Note:** Lubricate a bit the rod and the H0395 support  
Lock H0395, doing attention to the maximum smoothness  
of the carbon rod

**BOOM ASSEMBLY**

- \*Insert the tail boom assembly .
- \*Lock the M8 nuts with the HA016 special tool supplied (Tray 2).
- \*Firmly lock the lateral screws M3x12. Use Loctile for this screw and make sure you remain tight.
- \*Assemble the H0038 carbon security plate .
- \*Connect the Carbon Rod.

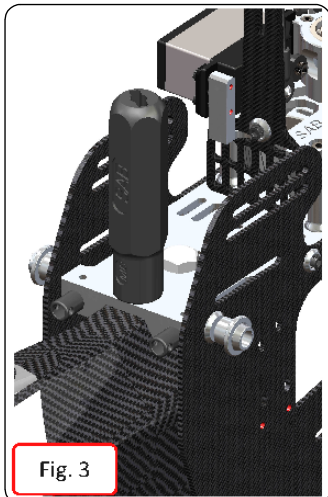
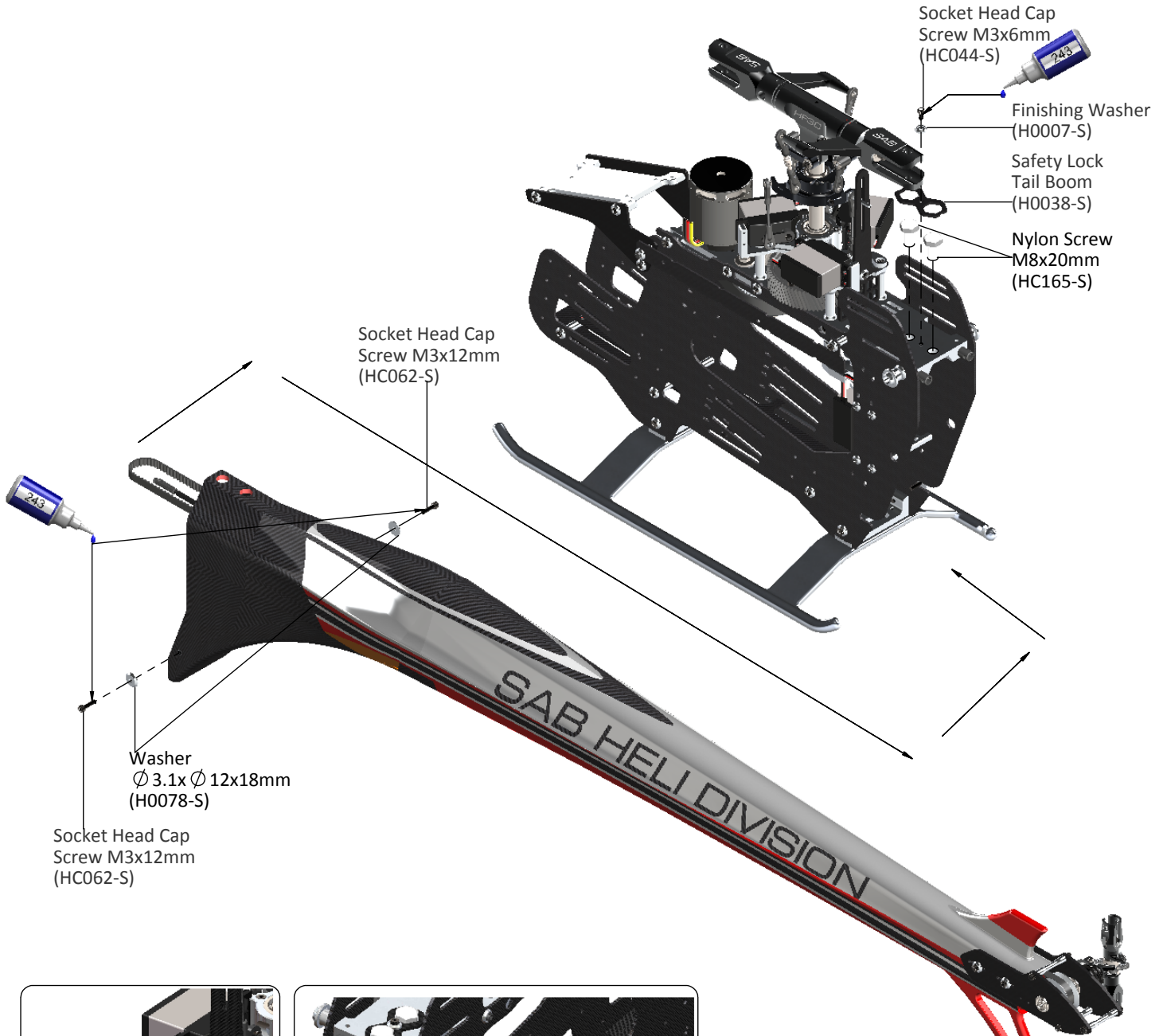

Fig. 3

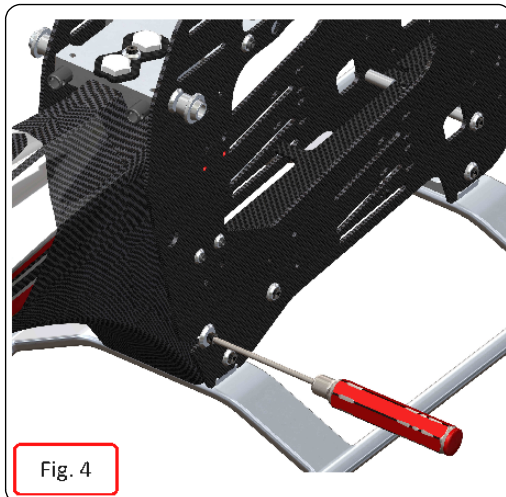
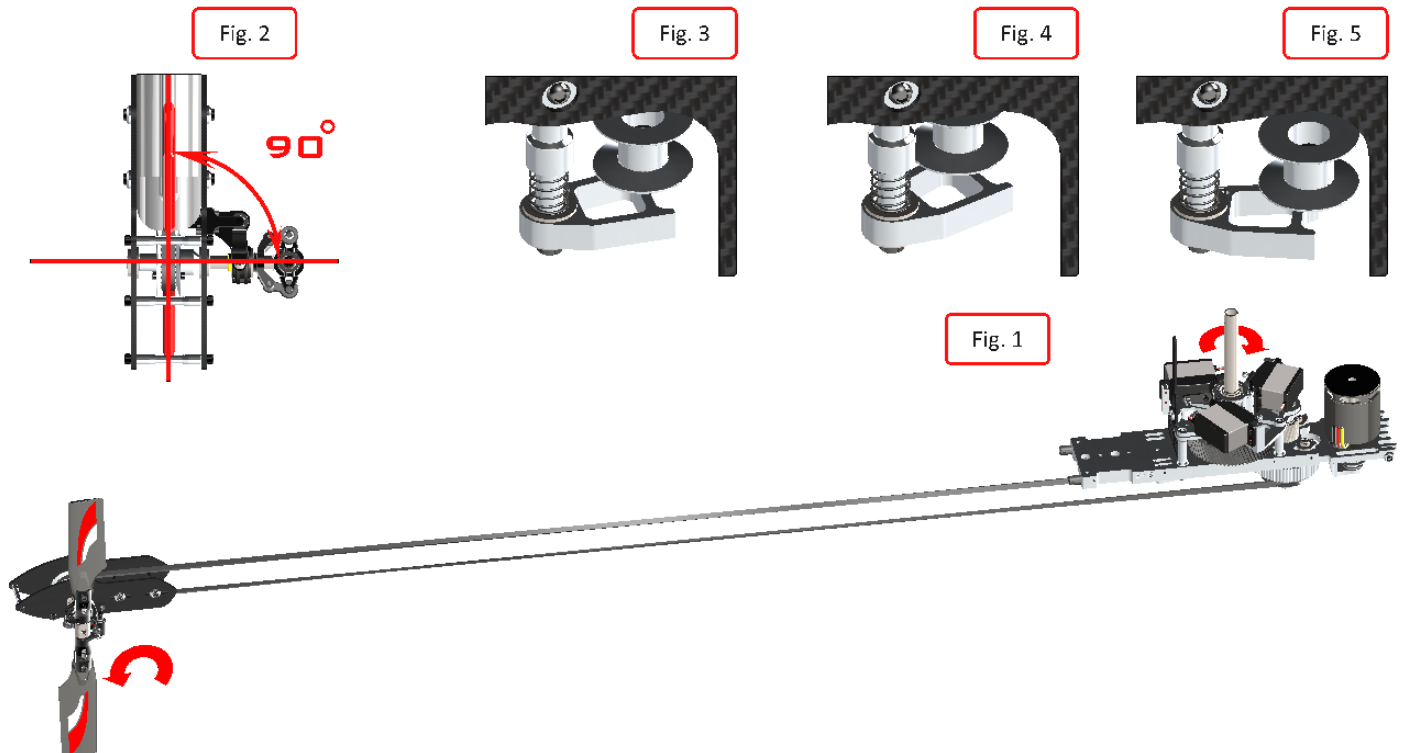

Fig. 4

**TAIL BELT TENSION**

- \*Check the proper assembly of the tail boom.
- \*Check that the aluminum part of the tube is against the M3 stop screw.
- \*Loosen the tail group by loosening the 4 M3 screws.
- \*Install the belt onto the pulley, taking care to respect the direction of rotation (**figure 1**).
- \*Rotate the tail drive several times by hand.
- \*Load the spring by a rotation of **270°** the tensioning arm (**clockwise**)
- \*Tension the boom until the tensioning arm is aligned with the frame.
- \*Tighten the 4 screws.
- \*Check that the tail output shaft is perpendicular to the tube. (**figure 2**)
- \*In **figure 3,4,5** you can see the three conditions, ok, too loose and too tight.

**NOTE.** To disassemble the tail boom it is possible to remove the pulley H0101-S without loosening the tail unit.  
Remove the locking screw and pull down.

**CANOPY**

The Goblin Urukay canopy has a very effective locking system in order to eliminate vibrations and optimize aerodynamics.

You must install the following to complete the canopy assembly:

- Canopy grommets (Fig 6), Canopy edge protection Fig 7 and Fig 8.

**The canopy hole must be 12 to 12.5 mm in diameter. Initially is 9 mm. You can enlarge the hole slightly to optimize the vertical position of the canopy itself.**

To install the canopy:

- Insert the canopy from the front up to the area of the block shown in Fig. 9
- Join the edges.
- Insert the H0036 knobs.



**Knoobs  
[H0036]**



Fig. 6



Fig. 7



Fig. 8

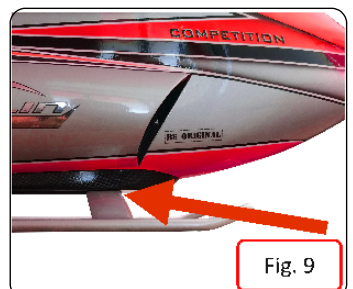

Fig. 9

**BATTERIES**

The battery tray system in the Goblin URUKAY is simple, but very effective. The battery should be attached to the tray (Part **H0149**) with heat shrink, tape or velcro. You can optionally use the battery protection tray (Part **H0151**) see **Fig. 1, 2**. Before permanently mounting the batteries onto the battery tray, check the ideal position for the best center of gravity. Cut the heat shrink around the carbon fiber tray locking pins. **Fig. 3**.

**Battery Pack:**

Slide the tray until it locks into the CNC stopper. **Fig. 4, 5**. Using the velcro straps, making sure that the two locking pins are stopped against the frame spacer (P/n #**H0003** and #**H0151**) **Fig. 6, 7**.

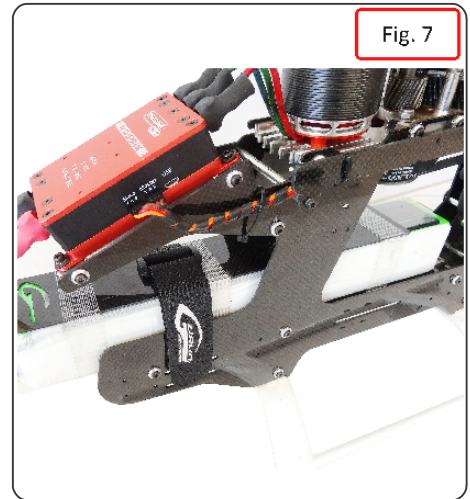
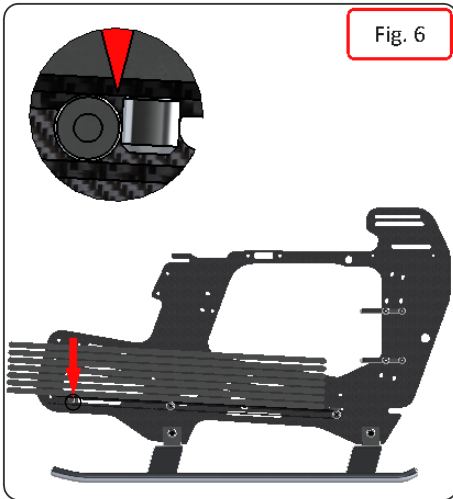
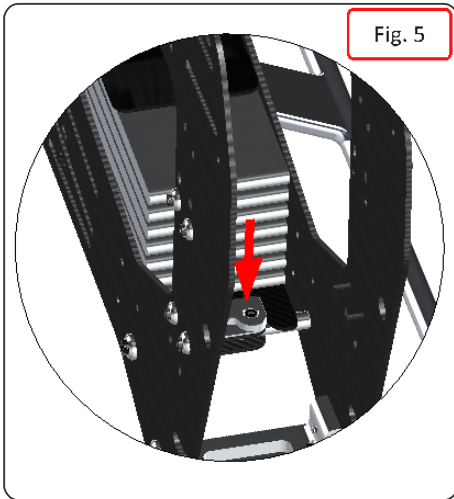
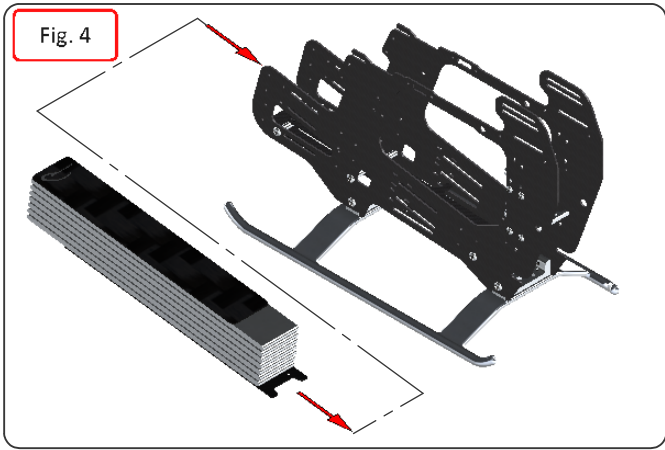
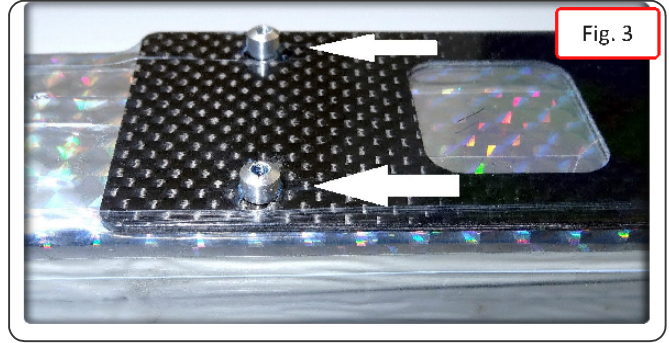
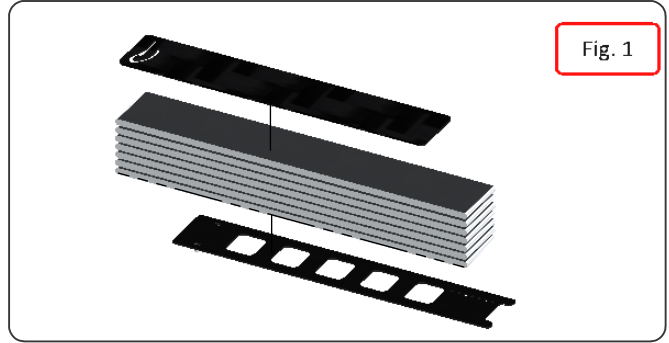
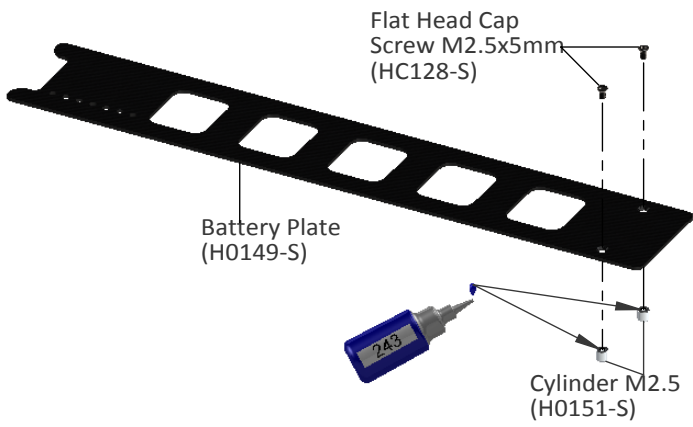

## OPERATIONS BEFORE FLIGHT

\*Set up the remote control and the flybarless system with utmost care.

\*It is advisable to test the correct settings of the remote and flybarless system without main blades and tail blades fitted.

\*Check that all wiring is isolated from the carbon/aluminum parts. It is good practice to protect them at the points where they are at most risk.

⚠ \*Be sure of the gear ratio, verifying carefully the motor pulley in use. The forces acting on the mechanics increase enormously with increasing of rpm. For safety reasons we suggest to not exceed 2000 rpm.

\*Fit the main blades and tail blades. (Fig.1 and Fig.2)

\*Please make sure the main blades are tight on the blade grips. Failure to tighten the blades properly can result in a boom strike. To fold the blades for storage, it is advisable to loosen them.

\*Check the collective and cyclic pitch.

\*It is important to check the correct tracking of the main blades.

\*On the Goblin, in order to correct the tracking, adjust the main link rod as shown in figure 3. This is provided with a right/left thread system that allows continuous fine adjustments of the length of the control rod; for this adjustment it is not necessary to detach the ball link.

⚠ \*Perform the first flight at a low headspeed, 1500/1600 RPM.  
After this first flight, do a general check of the helicopter. Verify that all screws are correctly tightened.

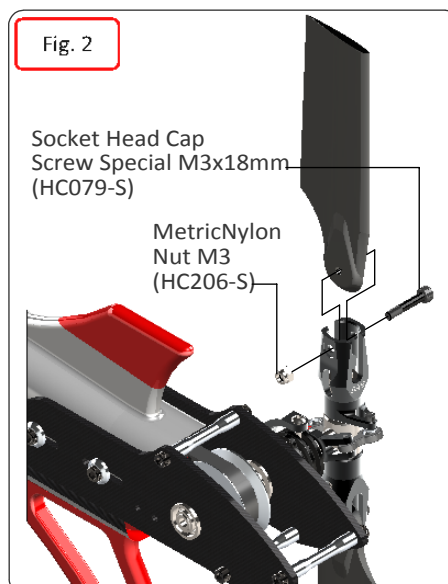

## IN FLIGHT

For hovering, it is recommended a headspeed of 1400-1500 rpm  
For normal flight, it is recommended a headspeed of 1900 rpm

It is possible change the rigidity of the dampening system. In the Kit, you can find Damper H0482-80 : 80 Shore ( Red ). You can change H0482-70 ( Yellow ), H0482-90 ( Green ), for change the head characteristic.

Changing the Damper, please check the Axial preload. The blade grips must move freely, but they should not move just under their own weight. You can remove / add the 0.2mm shim (HC232) from each side for to get perfect preload.

It is possible change the main rotor/tail rotor ratio  
In the Kit the tail pulley is 25T and the ratio is 5.3

Here the different option:

[H0102-S] 27T, ratio 4.9

[H0103-S] 26T, ratio 5.1

[H0154-S] 24T, ratio 5.5

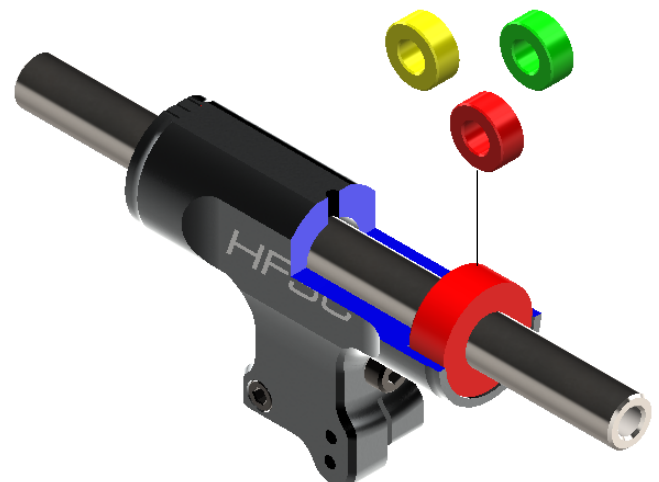

## MAINTENANCE

\*On the Goblin, areas to look for wear include:

- \* Motor belt
- \* Tail belt
- \* Damper
- \* Main gear and pinion

The lifespan of these components varies according to the type of flying. On average it is recommended to replace these special parts every **100** flights.

\*The head tends to lose rigidity after a while. Check this condition every **20** flights. Preloading with precision shim washers, it is possible to vary the rigidity of the head.

\*Check all uniballs often.

\*The most stressed bearings are definitely those of the tail shaft. Check them frequently. All other parts are not particularly subject to wear.

\*Periodically lubricate the tail slide movement and its linkages as well as the swashplate movement and its linkages.

\*Lubricate the main gear with proper Lubricant every 20 flights.

\*Check the screws that are highlighted in the following images frequently, make sure you remain tight ( **fig.2** and **fig.3**).

\*To ensure safety you should do a general inspection of the helicopter after each flight. You should check:

- \* The maintenance of proper belt tension.
- \* The proper isolation of wires from the carbon and aluminum parts.
- \* That all screws remain tight.

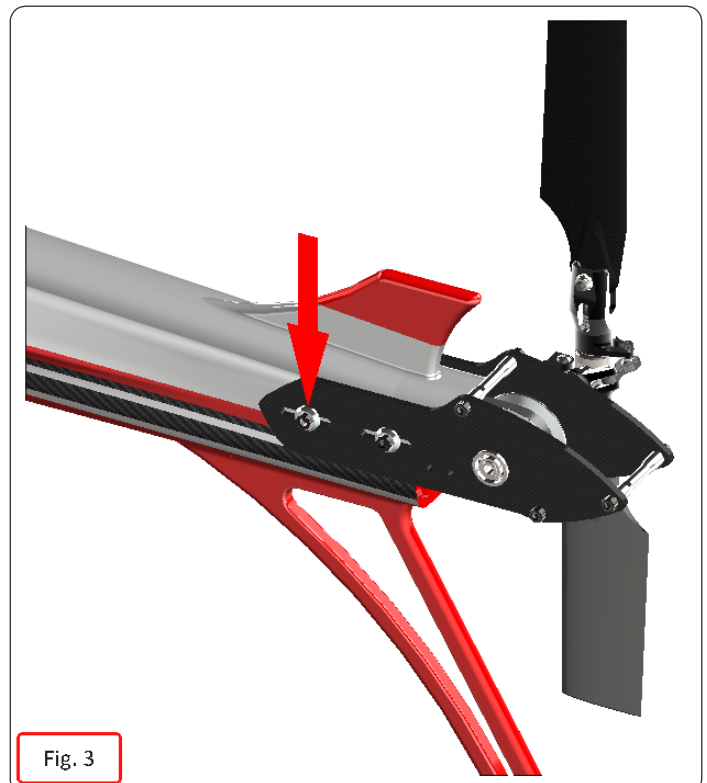
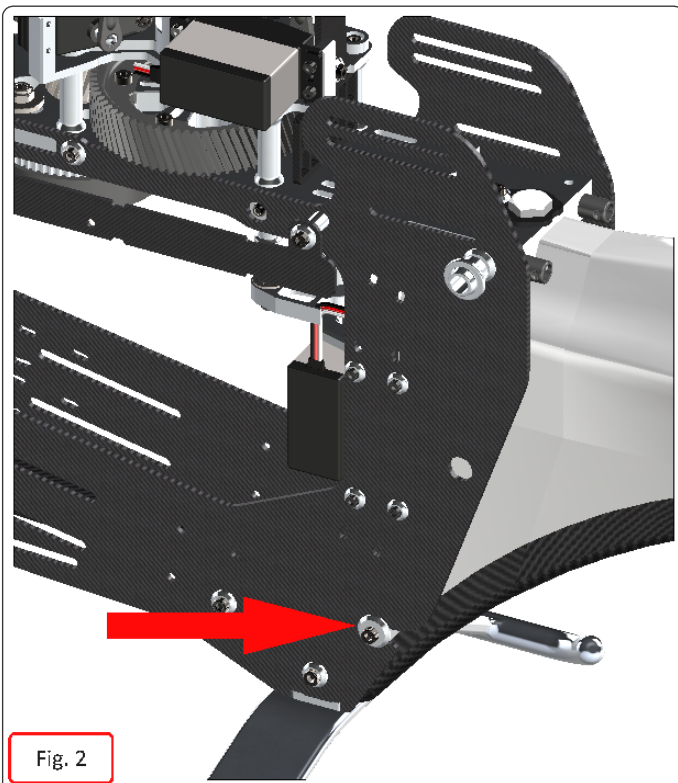



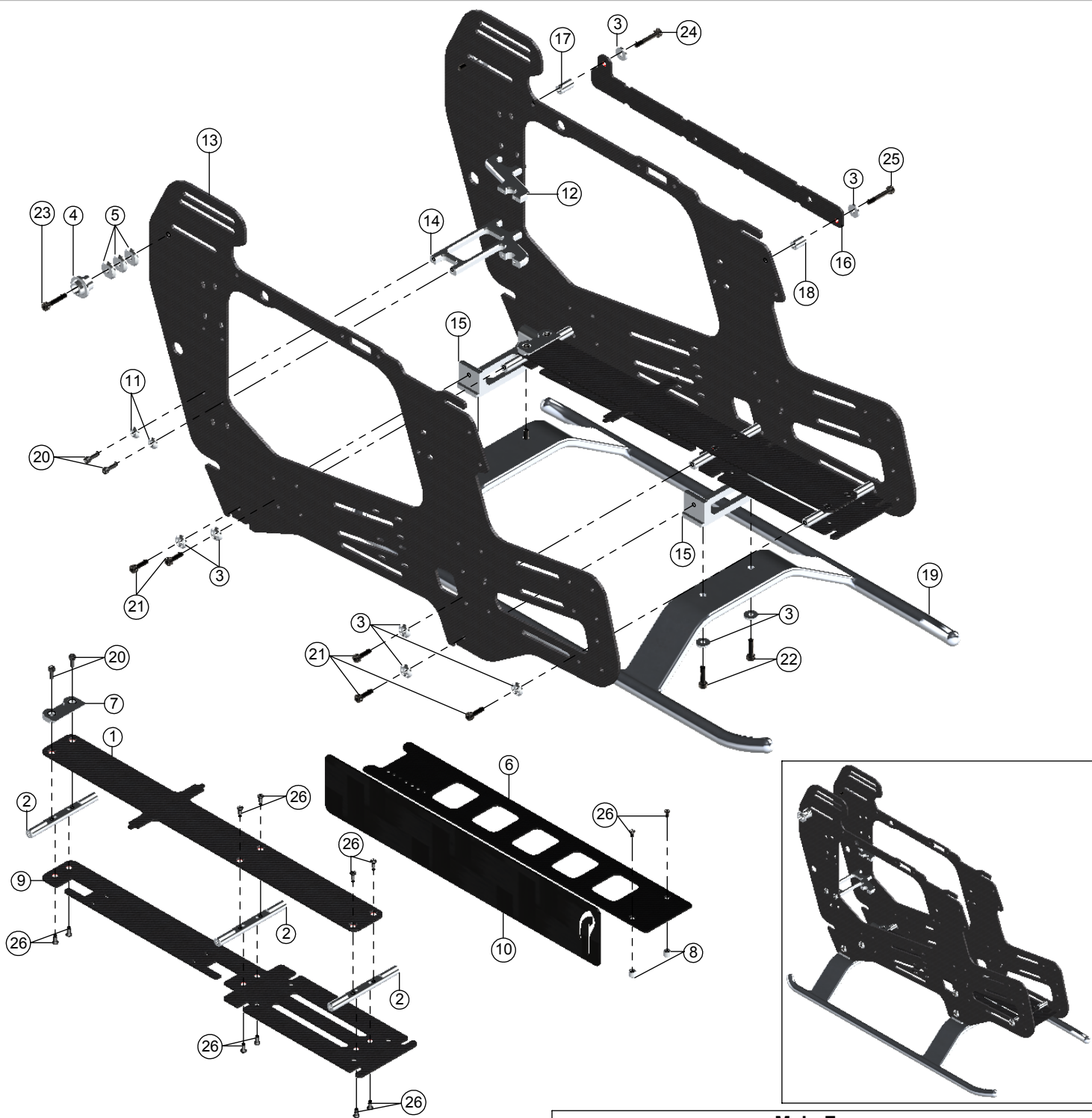

Main Frame				
POS	COD	Name	Specification	Quantity
1	H0002	Battery Tray	Carbon Fiber	1
2	H0003	Frame Spacers	Aluminum	3
3	H0007	Finishing Washers M3	Aluminum	20
4	H0008	Canopy Poitioner	Aluminum	2
5	H0078	Washer $\phi 3,1x \phi 1,2x1.8$	Aluminum	6
6	H0149	Battery Plate	Carbon Fiber	1
7	H0150	Stop Battery Plate	Aluminum	1
8	H0151	Cylinder M2.5	Aluminum	2
9	H0153	Battery Support	Carbon Fiber	1
10	H0153-1	Battery Protection	Carbon Fiber	1
11	H0255	Finishing Washers M2.5	Aluminum	6
12	H0436	Tail Servo Support	Aluminum	1
13	H0824	Main Frames	Carbon Fiber	2

Main Frame				
POS	COD	Name	Specification	Quantity
14	H0495	Tail Servo Support	Aluminum	1
15	H0496	Landing Gear Support	Aluminum	2
16	H0497	Wire Supports	Carbon Fiber	1
17	H0498	Spacer Wire 11mm	Aluminum	1
18	H0499	Spacer Wire 9mm	Aluminum	1
19	H0725	Landing Gear Silver		1
	H0639	Landing Gear White		
20	HC020	Socket Head Cap Screws	M2.5 x 8mm	8
21	HC056	Socket Head Cap Screws	M3 x 10mm	16
22	HC062	Socket Head Cap Screws	M3 x 12mm	4
23	HC068	Socket Head Cap Screws	M3 x 16mm	2
24	HC079	Head Cap Shoulder	M3x18mm	1
25	HC080	Head Cap Shoulder	M3x20mm	1
26	HC128	Flat Head Cap Screws	M2.5 x 5mm	12

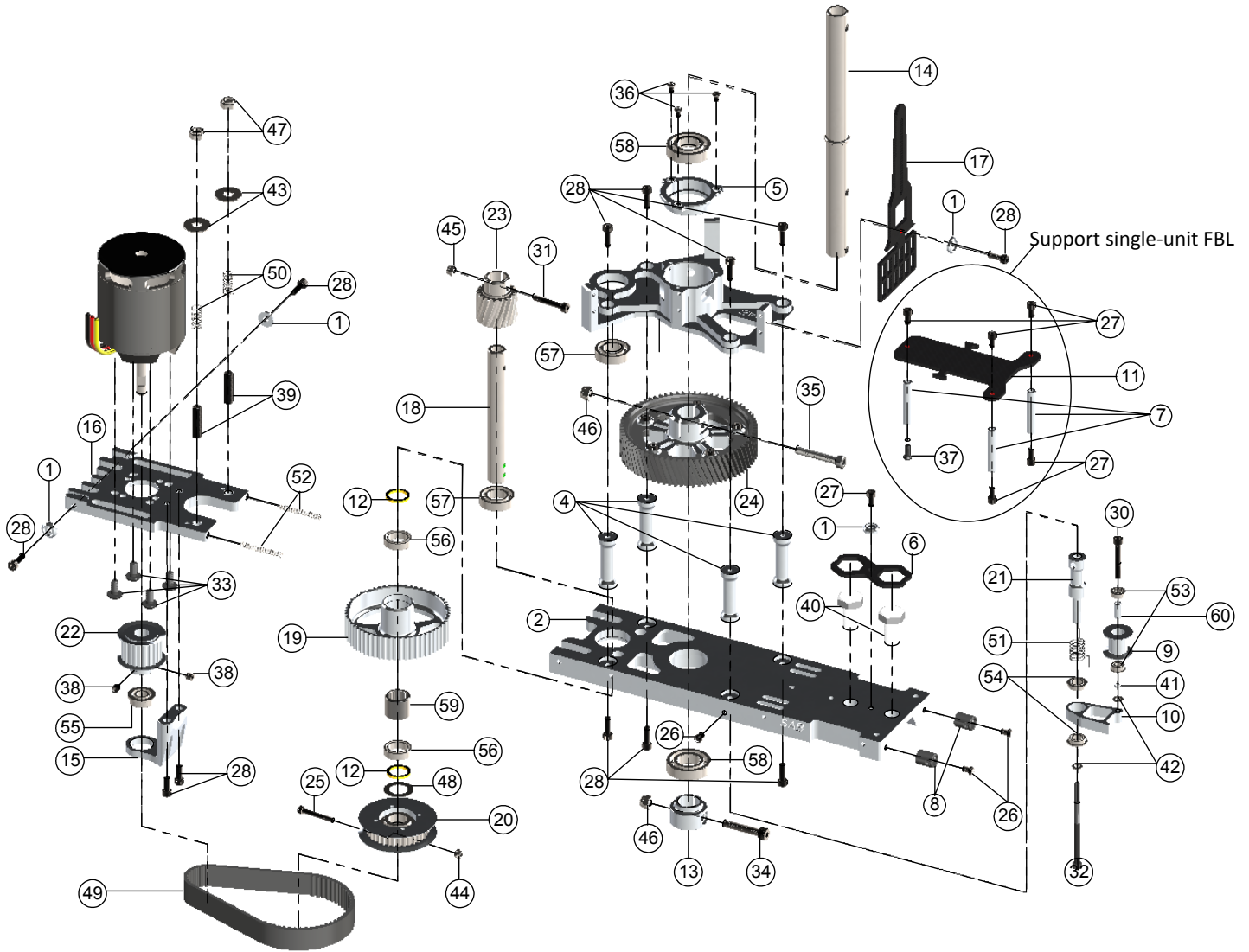

TRANSMISSION ASSEMBLY				
POS	COD	Name	Specification	Quantity
1	H0007	Finishing Washers M3	Aluminum	4
2	H0009	Main Structure	Aluminum	1
3	H0010	Servo Support	Aluminum	1
4	H0018	Columns	Aluminum	4
5	H0024	Main Shaft Bearing Support		1
6	H0038	Safety Locking Tail Boom	Carbon Fiber	1
7	H0043	Spacers Flybarless		3
8	H0050	Antenna Guide	Plastic	2
9	H0834	Tail Belt Idler		1
10	H0071	Belt Tensioner Arm		1
11	H0077	Flybarless Support	Carbon Fiber	1
12	H0110	Bush-One Ways	Ø10 x Ø13 x 1.4mm	2
13	H0121	M4 Locking Collar		1
14	H0127	Main Shaft		1
15	H0142	Support Bearing	Aluminum	1
16	H0143	Motor Support	Aluminum	1
17	H0152	Swash plate Anti-Rotation Guide	Carbon Fiber	1
18	H0157	Secondary Shaft		1
19	H0104	One Way Double Bearing	60T	1
20	H0101	Front Tail Pulley Low	37T	1
21	H0070	Column Belt Tensioner		1
22	H0126-20	Motor Pulley 20mm	20T	1
23	H0156	Drive Pinion	19T M1	1
24	H0405	Main Gear	68T M1	1
25	HC033	Socket Head Cap Screw Shouldered	M2.5 x 19mm	1
26	HC038	Button Head Cap Screws	M3 x 4mm	3
27	HC044	Socket Head Cap Screws	M3 x 6mm	6
28	HC050	Socket Head Cap Screws	M3 x 8mm	4
29	HC056	Socket Head Cap Screws	M3 x 10mm	9
30	HC080	Socket Head Cap Screw	M3 x 20mm	1
31	HC079	Socket Head Cap Screw	M3 x 18mm	1

TRANSMISSION ASSEMBLY				
POS	COD	Name	Specification	Quantity
32	HC092	Socket Head Cap Shouldered	m3 x 50mm	1
33	HC098	Button Head Cap Screws	M4 x 8mm	4
34	HC104	Socket Head Cap Screw	M4 x 22mm	1
35	HC111	Socket Head Cap Screw	M4 x 24mm	1
36	HC128	Flat Head Cap Screws	M2.5 x 5mm	3
37	HC134	Flat Head Cap Screw	M3 x 8mm	1
38	HC153	Set Screws	M4 x 6mm	1
39	HC158	Set Screws	M5 x 20mm	2
40	HC165	Vite Nylon Esa	M8 x 20mm	2
41	HC176	Washer	Ø3 x Ø4x0.5mm	1
42	HC180	Washers	Ø3.2 x Ø6 x 0.5mm	2
43	HC188	Washers	Ø5.3 x Ø15 x 1mm	2
44	HC200	Metric Hex Nylon Nuts	M2.5 H3.5mm	1
45	HC206	Metric Hex Nylon Nuts	M3 H4mm	1
46	HC212	Metric Hex Nylon Nuts	M4 H5mm	2
47	HC218	Metric Hex Nylon Nuts	M5 H4.8mm	2
48	HC232	Washer	Ø10 x Ø16 x 0.2mm	1
49	HC308	Big Motor Belt	240-3MGT	1
50	HC310	Springs	De 5.8-df0.3-LL9	2
51	HC312	Spring	De 8-df0.5-LL8	1
52	HC315	Springs	De 8-df0.5-LL12	2
53	HC402	Flanged Bearings	Ø3 x Ø7 x 3mm	2
54	HC410	Flanged Bearings	Ø5 x Ø9 x 3mm	2
55	HC414	Flanged Bearings	Ø6 x Ø13 x 5mm	1
56	HC420	Bearings	Ø10 x Ø15 x 4mm	2
57	HC422	Bearings	Ø10 x Ø19 x 5mm	2
58	HC426	Bearings	Ø12 x Ø24 x 6mm	2
59	HC442	One Way Bearing	Ø10 x Ø14 x 12mm	2
60	H0060	Bushing		1

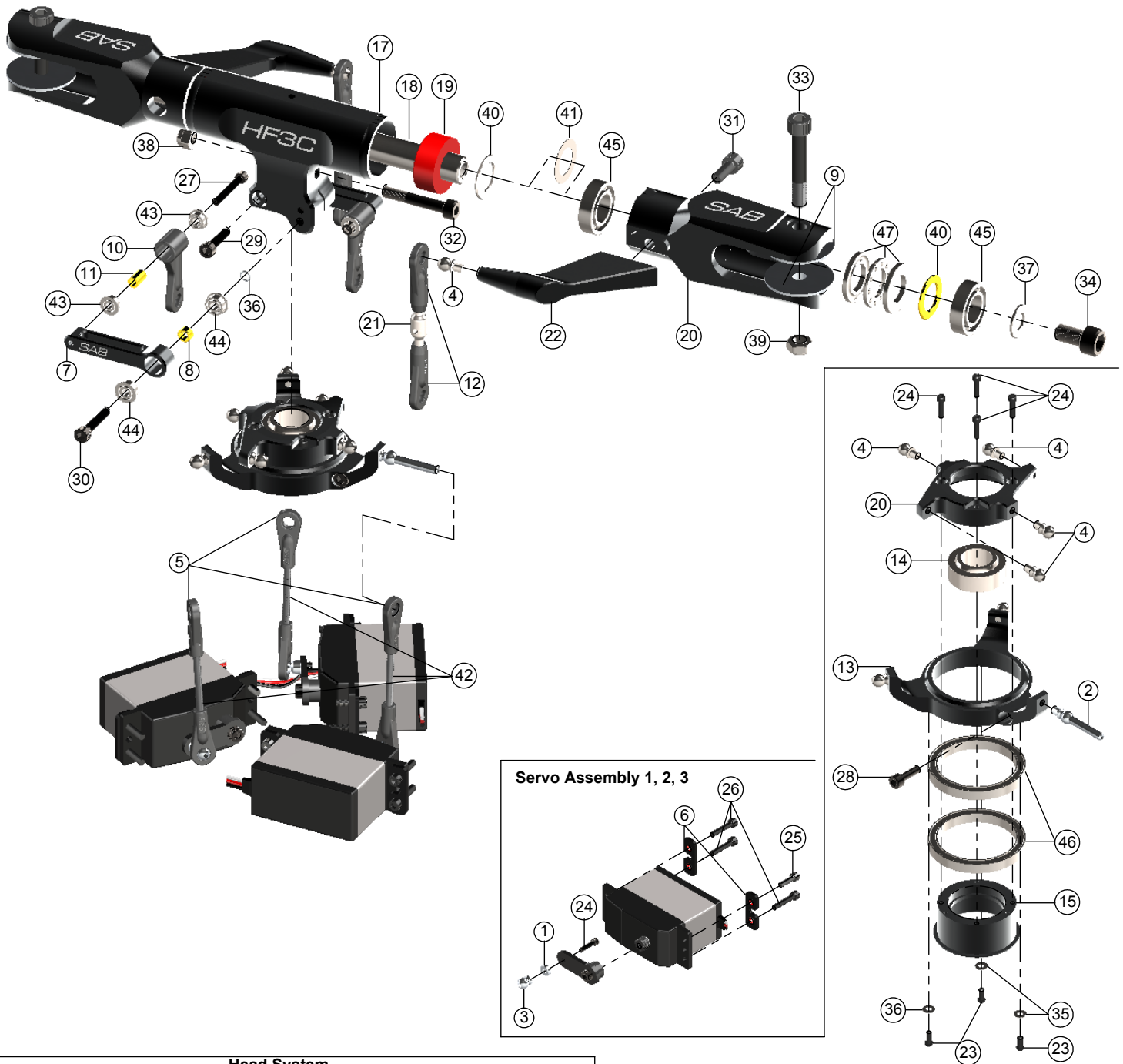

Head System				
Pos	Code	Name	Specification	Quantity
1	H0031	Uniball Spacers	Aluminum	3
2	H0063	Uniballs	M3x4 Ø5 H18	1
3	H0064	Uniballs	M2.5 Ø5 H6	3
4	H0065	Uniball M3	Steel	8
5	H0066	Plastic Ball Linkages	Plastic	6
6	H0075	Servo Spacers	Carbon Fiber	6
7	H0132BM	Radius Arm	Aluminum Black Matte	2
8	H0134	Spacer Arm		2
9	H0158	Blade Washers	Aluminum	4
10	H0205	Uniball Radius Arm	Plastic	2
11	H0253	Spacer Arm		2
12	H0402	Uniball M3	Plastic	4
13	H0420-01BM	Swashplate 01	Aluminum Black Matte	1
14	H0420-03	Swashplate 03	Steel	1
15	H0420-04BM	Swashplate 04	Aluminum Black Matte	1
16	H0422-02BM	Swashplate 02	Aluminum Black Matte	1
17	H0479BM	Center Hub	Aluminum Black Matte	1
18	H0481	Spindle	Steel	1
19	H0482-80	Damper	Red 80 shore	2
20	H0719BM	Main Blade Grip	Aluminum Black Matte	2
21	H0722	Main Linkages	Steel	2
22	H0817BM	Blade Grip Arm	Aluminum Black Matte	2
23	HC005	Button Cap Screws	M2x5mm	3
24	HC008	Head Cap Screws	M2 x 8mm	7



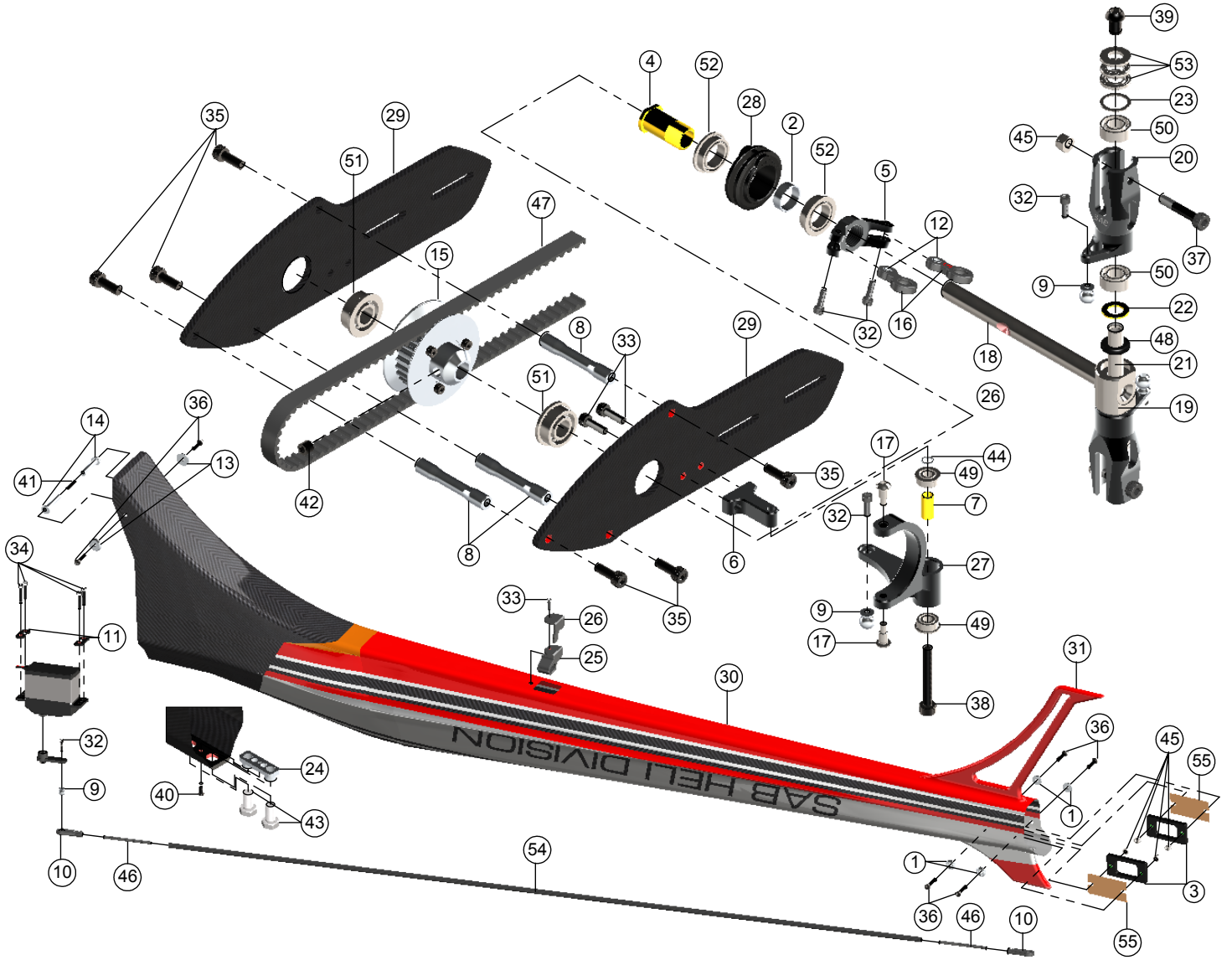







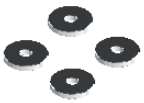

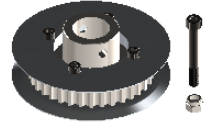
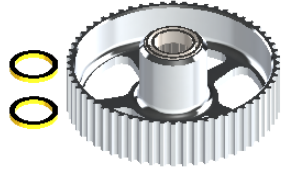





Head System				
Pos	Code	Name	Specification	Quantity
25	HC020	Head Cap Screws	M2.5x10mm	3
26	HC026	Head Cap Screws	M2.5x12mm	9
27	HC032	Head Cap Screws	M2.5x18mm	2
28	HC056	Head Cap Screws	M3x10mm	1
29	HC062	Head Cap Screws	M3x12mm	2
30	HC068	Head Cap Screws	M3x16mm	2
31	HC102	Head Cap Screws	M4x10mm	2
32	HC111	Head Cap Shoulder	M4x24mm	1
33	HC114	Head Cap Shoulder	M5x30mm	2
34	HC124	Head Cap Screws	M6x10mm	2
35	HC170	Washers	Ø2 x Ø5 x 0.5mm	3
36	HC176	Washers	Ø3x Ø4x0.5	2
37	HC194	Washers	Ø6x Ø14x1	2
38	HC212	Nylon Nut	M4	1
39	HC218	Nylon Nut	M5	2
40	HC230	Washers	Ø10x Ø16x1mm	4
41	HC232	Washers	Ø10x Ø16x0.2mm	2
42	HC242	threaded rods	M2.5 x 40mm	3
43	HC400	Flanged Bearing	Ø2.5x Ø6x2.5mm	4
44	HC402	Flanged Bearing	Ø3x Ø7x3mm	4
45	HC422	Bearing	Ø10x Ø19x5mm	4
46	HC430	Bearing Rads	Ø30 x Ø37 x 4mm	2
47	HC438	Thrust Bearing	Ø10x Ø18x5.5mm	2

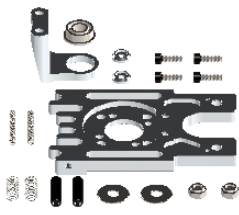
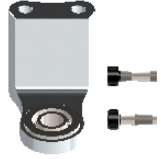
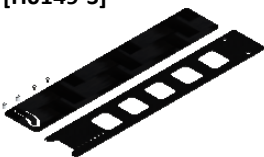

TAIL SYSTEM				
POS	COD	Name	Specification	Quantity
1	H0007	Finishing Washer M3	Aluminum	4
2	H0029	Spacer	∅8.1 x ∅9.2 x 3.2mm	1
3	H0041	Locking Element Tails	Carbon Fiber	2
4	H0054	Tail Pitch Slider 02	Aluminum	1
5	H0055BM	Tail Pitch Slider 01	Aluminum	1
6	H0058BM	Bell Crank Base	Aluminum	1
7	H0060	Spacer	∅3 x ∅4 x 9.6mm	1
8	H0061	Tail Case Spacers	Aluminum	3
9	H0064	Uniballs	M2.5 ∅5H6	4
10	H0066	Plastic Ball Links	Plastic	2
11	H0075	Servo Spacer	Carbon Fiber	2
12	H0076	Grip Link Bush	Aluminum	2
13	H0078	Washers	∅3.1 x ∅12 x 1.8mm	2
14	H0082	Boom spacers	Aluminum	2
15	H0155	Tail Pulley	25T	1
16	H0261	Tail Pitch Slider Link	Aluminum	2
17	H0264	Tail Pin		2
18	H0325	Tail Shaft		1
19	H0326	Tail Hub		1
20	H0327BM	Tail Blade Grip		2
21	H0329	Tail Spindle		1
22	H0330	Washer	∅5x∅9x0.75mm	2
23	H0349	Washer	∅7.5x∅10x0.5mm	2
24	H0358	Block Nut		1
25	H0394	Carbon Rod Support		1
26	H0395	Carbon Rod Support B		1
27	H0406BM	Bell Crank Lever	Aluminum	1
28	H0407	Tail Pitch Slider 02	Black Derlin	1

TAIL SYSTEM				
POS	COD	Name	Specification	Quantity
29	H0494	Carbon Tail Side Plate	Carbon Fiber	2
30	H0822	Tail Boom Ennio Edition		1
	H0724	Tail Boom Silver		
31	H0823	Red Tail Fin		1
32	HC004	Socket Head Cap Screws	M2 x 6mm	6
33	HC020	Socket Head Cap Screws	M2.5 x 8mm	3
34	HC026	Socket Head Cap Screws	M2.5 x 12mm	4
35	HC050	Socket Head Cap Screws	M3 x 8mm	6
36	HC062	Socket Head Cap Screws	M3 x 12mm	6
37	HC079	Socket Head Cap Shoudered	M3 x 18mm	2
38	HC086	Socket Head Cap Screws	M3 x 22mm	1
39	HC096	Button Head Cap Screws	M4 x 6mm	2
40	HC134	Flat Head Cap Screws	M3x8mm	1
41	HC150	Set Screws	M3 x 20mm	1
42	HC153	Set Screws	M4 x 6mm	1
43	HC165	Nylon Screw	M8x20mm	2
44	HC176	Washer		1
45	HC206	Metric Hex Nylon Nuts	M3	6
46	HC242	Threaded Rods	M2.5 x 40mm	2
47	HC325	Belt Gates		1
48	HC335	Oring		2
49	HC402	Flanged Bearings	∅3 x ∅7 x 3mm	2
50	HC411	Bearings	∅5x∅10x4mm	4
51	HC414	Flanged Bearings	∅6 x ∅13 x 5mm	2
52	HC418	Flanged Bearings	∅8 x ∅12 x 3.5mm	2
53	HC435	Thrust Bearings	∅5x∅10x4mm	2
54	HC451	Carbon Rod		1
55	HA015	Double-Sided Tapes		2

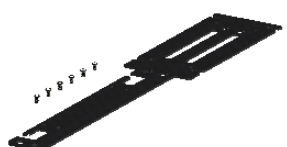































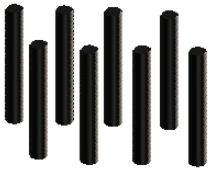

				
<b>Battery Tray</b> [H0002-S]  - 1 x CF Battery Tray. - 6 x Flat Head Cap Screws M2.5x5mm.	<b>Frame Spacer</b> [H0003-S]  - 3 x Frame Spacers.	<b>Finishing Washer M3</b> [H0007-S]  - 10 x Finishing Washers .	<b>Canopy Positioner</b> [H0008-S]  - 2 x Canopy Positioner .	<b>Main Structure</b> [H0009-S]  - 1 x Main Structure.
<b>Servo Support</b> [H0010-S]  - 1 x Servo Support.	<b>Column</b> [H0018-S]  - 4 x Columns.	<b>Bearing Support</b> [H0024-S]  - 1 x Bearing Support. - 1 x Bearing $\varnothing 12 \times \varnothing 24 \times 6 \text{mm}$ . - 3 x Flat Head Cap Screws M2.5x5mm.	<b>Canopy Knobs</b> [H0036-S]  - 2 x Canopy Knobs.	<b>Safety Lock Tail Boom</b> [H0038-S]  - 1 x Safety Lock Tail Boom. - 1 x Finishing Washer M3. - 1 x Socket Head Cap Screws M3x8mm.
<b>Locking Element Tail</b> [H0041-S]  - 2 x Locking Element Tails. - 4 x Metric Hex Nylon Nuts M3. - 2 x Double Sided Tapes.	<b>Spacer Flybarless</b> [H0043-S]  - 3 x Spacer Flybarless. - 1 x Supporto Flybarless. - 1 x Flat Head Cap Screws M3x8mm. - 5 x Socket Head Cap Screws M3x6mm.	<b>Antenna Guide</b> [H0050-S]  - 2 x Antenna Guide. - 2 x Button Head Cap Screws M3x4mm.	<b>Bell Crank Base</b> [H0058BM-S]  - 1 x Bell Crank Base.	
<b>Tail Case Spacer</b> [H0061-S]  - 2 x Tail Case Spacers. - 4 x Socket Head Cap Screws M3x8mm.	<b>Uniball M3x4 <math>\varnothing</math> 5H18</b> [H0063-S]  - 1 x Uniball M3x4 $\varnothing$ 5H18.	<b>Uniball M2 <math>\varnothing</math> 5H6</b> [H0064-S]  - 5 x Uniballs M2 $\varnothing$ 5H6. - 5 x Uniball Spacers. - 5 x Socket Head Cap Screws M2x8mm. - 5 x Socket Head Cap Screws M2x6mm.	<b>Uniball M3x4 <math>\varnothing</math> 5H3</b> [H0065-S]  - 5 x Uniballs M3x4 $\varnothing$ 5H3.5.	
<b>Plastic Ball Link</b> [H0066-S]  - 10 x Plastic Ball Link.	<b>Belt Tensioner Support</b> [H0834-S]  - 1 x Column Belt Tensioner. - 1 x Tail Belt Idler. - 1 x Belt Tensioner Arm. - 2 x Flanged Bearings $\varnothing 3 \times \varnothing 7 \times 3 \text{mm}$ . - 2 x Flanged Bearings $\varnothing 5 \times \varnothing 9 \times 3 \text{mm}$ . - 1 x Socket Head Cap Screw M3x50mm. - 1 x Washer $\varnothing 3 \times \varnothing 4 \times 0.5 \text{mm}$ . - 1 x Socket Head Cap Screw M3x12mm. - 2 x Washers $\varnothing 3.2 \times \varnothing 6 \times 0.5 \text{mm}$ . - 1 x Button Head Cap Screw M3x4mm. - 1 x Spring De8/df0.5/LL8.	<b>Servo Spacer</b> [H0075-S]  - 10 x Servo Spacers.		

<p><b>Washer</b>  <math>\varnothing 3.1 \times \varnothing 12 \times 1.8 \text{mm}</math>  <b>[H0078-S]</b></p>  <p>- 10 x Washers  <math>\varnothing 3.1 \times \varnothing 12 \times 1.8</math>.</p>	<p><b>Boom Spacer</b>  <b>[H0082-S]</b></p>  <p>- 2 x Boom Spacer.  - 1 x Set Screw M3x20.</p>	<p><b>Front Tail Pulley</b>  <b>[H0101-S]</b></p>  <p>- 1 x Front Tail Pulley.  - 1 x Socket Head M2.5x19mm.  - 1 x Metric Nylon Nuts M2,5.</p>	<p><b>One Way Pulley</b>  <b>[H0104-S]</b></p>  <p>- 2 x Brass Bushing.  - 2 x Radial Bearings <math>\varnothing 10 \times \varnothing 15 \times 4 \text{mm}</math>.  - 1 x One Way Bearing <math>\varnothing 10 \times \varnothing 14 \times 12 \text{mm}</math>.  - 1 x Aluminum Pulley 60T.</p>	<p><b>Bush One Way</b>  <b>[H0110-S]</b></p>  <p>- 4 x Bush One Ways.</p>
<p><b>M4 Locking Collar</b>  <b>[H0121-S]</b></p>  <p>- 1 x M4 Locking Collar.  - 1 x Socket Head Cap Screw M4x22mm.  - 1 x Nylon Nut M4.</p>	<p><b>18T Pulley</b>  <b>[H0126-18-S]</b></p>  <p>- 1 x 18T Pulley.  - 2 x Set Screws M4x4mm.</p>	<p><b>19T Pulley</b>  <b>[H0126-19-S]</b></p>  <p>- 1 x 19T Pulley.  - 2 x Set Screws M4x4mm.</p>	<p><b>19T Pulley</b>  <b>[H0126-20-S]</b></p>  <p>- 1 x 20T Pulley.  - 2 x Set Screws M4x4mm.</p>	<p><b>19T Pulley</b>  <b>[H0126-21-S]</b></p>  <p>- 1 x 21T Pulley.  - 2 x Set Screws M4x4mm.</p>
<p><b>19T Pulley</b>  <b>[H0126-22-S]</b></p>  <p>- 1 x 22T Pulley.  - 2 x Set Screws M4x4mm.</p>	<p><b>19T Pulley</b>  <b>[H0126-23-S]</b></p>  <p>- 1 x 23T Pulley.  - 2 x Set Screws M4x4mm.</p>	<p><b>19T Pulley</b>  <b>[H0126-24-S]</b></p>  <p>- 1 x 24T Pulley.  - 2 x Set Screws M4x4mm.</p>	<p><b>Main Shaft</b>  <b>[H0127-S]</b></p>  <p>- 1 x Main Shaft.  - 1 x M4 Locking Collar.  - 1 x Socket Head Cap Screw Shouldered M4x24mm.  - 2 x Socket Head Cap Screws M4x22mm.  - 3 x Nylon Nuts M4.</p>	
<p><b>Radius Arm</b>  <b>[H0132-S]</b></p>  <p>- 2 x Radius Arms.  - 2 x Spacer Arm <math>\varnothing 3 \times \varnothing 5 \times 2.7 \text{mm}</math>.  - 2 x Spacer Arm <math>\varnothing 2.5 \times \varnothing 4 \times 6.3 \text{mm}</math>.  - 2 x Uniball Radius Arms.  - 2 x Socket Head Cap Screws M3x16mm.  - 2 x Socket Head Cap Screws M2.5x18mm.  - 2 x Washers <math>\varnothing 3 \times \varnothing 4 \times 0.5 \text{mm}</math>.  - 2 x Flanged Bearings <math>\varnothing 2.5 \times \varnothing 6 \times 2.5 \text{mm}</math>.  - 2 x Flanged Bearings <math>\varnothing 3 \times \varnothing 7 \times 3 \text{mm}</math>.</p>		<p><b>Motor Mount</b>  <b>[H0142-S]</b></p>  <p>- 1 x Bearing 3° Support.  - 1 x Motor Support.  - 1 x Flanged Bearing <math>\varnothing 6 \times \varnothing 13 \times 5 \text{mm}</math>.  - 2 x Head Cap Screws M3x8.  - 2 x Set Screws M5x20mm.  - 2 x Washers <math>\varnothing 5.3 \times \varnothing 15 \times 1</math>.  - 2 x Nylon Nuts M5H4.8.  - 2 x Finishing Washers M3.  - 2 x Head Cap Screws M3x10.  - 2 x Nylon Nut M3 H4.  - 2 x Springs de 5.8/ df0.5 / LL9.  - 2 x Springs de 3/ df0.5 / LL12.</p>	<p><b>Bearing Support</b>  <b>[H0143-S]</b></p>  <p>- 1 x Bearing 3° Support.  - 1 x Flanged Bearing <math>\varnothing 6 \times \varnothing 13 \times 5 \text{mm}</math>.  - 2 x Socket Head Cap Screws M3x8mm.</p>	
<p><b>Battery Tray</b>  <b>[H0149-S]</b></p>  <p>- 1 x Battery Plate.  - 1 x Battery Protection.  - 2 x Cylinder M2.5.  - 2 x Flat Head Cap Screw M2.5x5mm.  - 1 x Heat Shrink.</p>	<p><b>Stop Battery Tray</b>  <b>[H0150-S]</b></p>  <p>- 1 x Stop Battery Tray.  - 2 x Socket Head Cap Screws M2.5x8mm.</p>	<p><b>Swashplate Anti-Rotation Guide</b>  <b>[H0152-S]</b></p>  <p>- 1 x CF Swashplate Anti-Rotation Guide.  - 1 x Finishing Washer M3.  - 1 x Socket Head Cap Screw M3x8mm.</p>	<p><b>Carbon Fiber ESC Support</b>  <b>(H0153-S)</b></p>  <p>- 1 x ESC Support.  - 6 x Flat Head Socket Cap M2,5x5mm.</p>	<p><b>24T Tail Pulley</b>  <b>[H0154-S]</b></p>  <p>- 1 x 24T Tail Pulley.  - 1 x Set Screw M4x4mm.  - 6 x Socket Head Cap Screws M2x5mm.</p>

				
<p><b>25T Tail Pulley</b> [H0155-S]</p>  <ul style="list-style-type: none"> <li>- 1 x 25T Tail Pulley.</li> <li>- 1 x Set Screw M4x4mm.</li> <li>- 6 x Socket Head Cap Screws M2x5mm.</li> </ul>	<p><b>Steel Pinion Z19</b> [H0156-S]</p>  <ul style="list-style-type: none"> <li>- 1 x Steel Pinion Z19.</li> <li>- 1 x Socket Head Cap M3x22 Shoulder.</li> <li>- 1 x Metric hex locknut Nuts M3H4.</li> </ul>	<p><b>Secondary Shaft</b> [H0157-S]</p>  <ul style="list-style-type: none"> <li>- 1 x Secondary Shaft M3.</li> <li>- 1 x Head Cap Shouldered M2.5x19mm.</li> <li>- 1 x Nylon Nut M2,5</li> <li>- 1 x Head Cap Shouldered M3x22mm.</li> <li>- 1 x Nylon Nuts M3.</li> </ul>	<p><b>Aluminum Blade Spacer</b> [H0158-S]</p>  <ul style="list-style-type: none"> <li>- 4 x Aluminum Blade Spacer.</li> </ul>	<p><b>Plastic Radius Arm</b> [H0205-S]</p>  <ul style="list-style-type: none"> <li>- 2 x Plastic Radius Arm.</li> </ul>
<p><b>Finishing Washer M2.5</b> [H0255-S]</p>  <ul style="list-style-type: none"> <li>- 10 x Washer M2.5.</li> </ul>	<p><b>Plastic Tail Linkage</b> [H0261-S]</p>  <ul style="list-style-type: none"> <li>- 2 x Plastic Tail Linkage.</li> <li>- 2 x Grip Link Bushing.</li> <li>- 2 x Socket Head Cap Screws M2x6mm.</li> </ul>	<p><b>Steel Tail Shaft</b> [H0325-S]</p>  <ul style="list-style-type: none"> <li>- 1 x Tail Shaft Assembly.</li> <li>- 2 x Tail Oring Dampener.</li> </ul>	<p><b>Aluminum Tail Blade Grip</b> [H0327BM-S]</p>  <ul style="list-style-type: none"> <li>- 2 x Aluminum Tail Blade Grip.</li> <li>- 4 x Bearing <math>\varnothing 5 \times \varnothing 10 \times 4</math>mm.</li> <li>- 2 x Thrust bearing <math>\varnothing 5 \times \varnothing 10 \times 4</math>mm.</li> <li>- 2 x Button Head Cap M4x8mm.</li> <li>- 2 x Socket Head Cap M2x6mm.</li> <li>- 2 x Washer <math>\varnothing 5 \times \varnothing 8.9 \times 0,75</math>mm.</li> <li>- 2 x Washer <math>\varnothing 7.5 \times \varnothing 10 \times 0,5</math>mm.</li> </ul>	
<p><b>Tail Spilde Shaft</b> [H0329-S]</p>  <ul style="list-style-type: none"> <li>- 1 x Tail Spilde Shaft.</li> <li>- 2 x Button Head Cap Screws M4x6mm.</li> </ul>	<p><b>Spacer Set For Tail Rotor</b> [H0330-S]</p>  <ul style="list-style-type: none"> <li>- 2 x Washer <math>\varnothing 5 \times \varnothing 8.9 \times 0,75</math>mm.</li> <li>- 2 x Washer <math>\varnothing 7.5 \times \varnothing 10 \times 0,5</math>mm.</li> <li>- 2 x Tail Oring Dampener.</li> </ul>	<p><b>Tail Boom Support</b> [H0358-S]</p>  <ul style="list-style-type: none"> <li>- 1 x Tail Boom Support.</li> <li>- 1 x Nylon screw M8x20.</li> <li>- 1 x Flat Head Cap Screws M3x8mm.</li> </ul>	<p><b>Tail Boom Support</b> [H0394-S]</p>  <ul style="list-style-type: none"> <li>- 1 x Plastic Carbon Rod Support.</li> <li>- 1 x Finishing Washer M2.5.</li> <li>- 1 x Socket Head Cap Screws M2,5x10mm.</li> </ul>	<p><b>Ball Link</b> [H0402-S]</p>  <ul style="list-style-type: none"> <li>- 5 x Ball Link.</li> </ul>
<p><b>CNC Delrin Main Gear</b> [H0405-S]</p>  <ul style="list-style-type: none"> <li>- 1 x CNC Delrin Main Gear.</li> </ul>	<p><b>Bell Crank Lever</b> [H0406BM-S]</p>  <ul style="list-style-type: none"> <li>- 2 x Tail Pin.</li> <li>- 1 x Uniball M2.</li> <li>- 1 x Uniball Spacer.</li> <li>- 1 x Bell Crank Lever.</li> <li>- 2 x Flanged Bearing <math>\varnothing 3 \times \varnothing 7 \times 3</math>mm.</li> <li>- 1 x Head Cap Screws M3x22mm.</li> <li>- 1 x Head Cap Screws M2x8mm.</li> <li>- 1 x Washer <math>\varnothing 3 \times \varnothing 4 \times 0.5</math>mm.</li> <li>- 1 x Spacer 3 x 4 x 9.6mm.</li> </ul>	<p><b>Tail Pitch Slider</b> [H0407BM-S]</p>  <ul style="list-style-type: none"> <li>- 1 x Tail Pitch Slider 01.</li> <li>- 1 x Tail Pitch Slider 02.</li> <li>- 1 x Tail Pitch Slider 03.</li> <li>- 1 x Spacer <math>\varnothing 8 \times \varnothing 9 \times 3.2</math>mm.</li> <li>- 2 x Flanged Bearings <math>\varnothing 8 \times \varnothing 12 \times 3.5</math>mm</li> </ul>		<p><b>SwashPlate Set</b> [H0422BM-S]</p>  <ul style="list-style-type: none"> <li>- 1 x Swashplate Assembly SET.</li> </ul>
<p><b>Tail Servo Support</b> [H0436-S]</p>  <ul style="list-style-type: none"> <li>- 2 x Tail Servo Support.</li> </ul>	<p><b>Top Position ESC Support</b> [H0450-S]</p>  <ul style="list-style-type: none"> <li>- 4 x Set Screws M3X20.</li> <li>- 4 x Nylon Nut M3.</li> <li>- 2 x Carbon Fiber Top ESC Support.</li> <li>- 1 x Aluminum Top ESC Support.</li> <li>- 4 x Socket Screw M3x8.</li> <li>- 4 x Socket Screw M3x10.</li> <li>- 8 x Aluminum Washer M3.</li> <li>- 12 x Washer <math>\varnothing 3,3 \times \varnothing 6 \times 0.5</math>mm.</li> </ul>		<p><b>Center Hurb</b> [H0479BM-S]</p>  <ul style="list-style-type: none"> <li>- 1 x Center Hub.</li> <li>- 2 x Socket Head Cap Screws M3x12mm.</li> <li>- 1 x Socket Head Cap Screw Shouldered M4x24mm.</li> <li>- 1 x Metric Hex Nylon Nut M4.</li> </ul>	

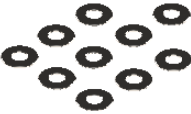
<p><b>Spindle [H0481-S]</b></p> <ul style="list-style-type: none"> <li>- 1 x Spindle.</li> <li>- 2 x Head Cap Screw M6x10.</li> <li>- 2 x Washer Ø6xØ14x1.5.</li> </ul>	<p><b>Damper [H0482-60-S]</b></p> <ul style="list-style-type: none"> <li>- 1 x Damper 60 Shore.</li> </ul>	<p><b>Damper [H0482-70-S]</b></p> <ul style="list-style-type: none"> <li>- 1 x Damper 70 Shore.</li> </ul>	<p><b>Damper [H0482-80-S]</b></p> <ul style="list-style-type: none"> <li>- 1 x Damper 80 Shore.</li> </ul>	<p><b>Damper [H0482-90-S]</b></p> <ul style="list-style-type: none"> <li>- 1 x Damper 90 Shore.</li> </ul>
<p><b>Carbon Tail Side Plate [H0494-S]</b></p> <ul style="list-style-type: none"> <li>- 2 x CarbonTail Side Plate.</li> <li>- 2 x Flanged Bearing Ø6xØ13x5mm.</li> </ul>	<p><b>Tail Servo Support [H0495-S]</b></p> <ul style="list-style-type: none"> <li>- 1 x Tail Servo Support.</li> </ul>	<p><b>Landing Gear Support [H0496-S]</b></p> <ul style="list-style-type: none"> <li>- 2 x Landing Gear Support.</li> </ul>	<p><b>Wire Support [H0497-S]</b></p> <ul style="list-style-type: none"> <li>- 1 x Wire Support.</li> <li>- 1 x Spacer Wire 11mm.</li> <li>- 1 x Spacer Wire 9mm.</li> <li>- 2 x Head Cap Shoulder M3x18mm.</li> </ul>	
<p><b>Landing Gear White [H0639-S]</b></p> <ul style="list-style-type: none"> <li>- 1 x Landing Gear White.</li> <li>- 4 x Head Cap Screw M3x12.</li> <li>- 4 x Aluminum Washer M3.</li> </ul>	<p><b>Main Blade Grip [H0719BM-S]</b></p> <ul style="list-style-type: none"> <li>- 1 x Main Blade Grip.</li> <li>- 2 x Bearing Ø10xØ19x5.</li> <li>- 1 x Thrust Bearing Ø10xØ18x5,5.</li> <li>- 1 x Shims Ø10xØ16x 1.</li> <li>- 1 x Head Cap Screw M4x10.</li> </ul>	<p><b>Titanium Main Linkage [H0722-S]</b></p> <ul style="list-style-type: none"> <li>- 2 x Titanium Main Linkage.</li> <li>- 4 x Plastic Ball Link.</li> </ul>	<p><b>Canopy Urukay Carbon [H0723-S]</b></p> <ul style="list-style-type: none"> <li>- 1 x Canopy Urukay Carbon.</li> <li>- 2 x Canopy Grommet.</li> <li>- 1 x Canopy Mousse.</li> <li>- 3 x Canopy Edge Protection.</li> </ul>	
<p><b>Boom Urukay Carbon [H0724-S]</b></p> <ul style="list-style-type: none"> <li>- 1 x Tail Boom Ennio Graber Edition.</li> <li>- 2 x Locking Element Tails.</li> <li>- 1 x Set Screws M3 x 20mm.</li> <li>- 2 x Washers 3.1 x 12 x 1.8mm.</li> <li>- 4 x Metric Hex Nylon Nuts M3.</li> <li>- 2 x Head Cap Screws M3x12mm.</li> <li>- 2 x Nylon Screw M8x20mm.</li> <li>- 1 x Flat Head Cap Screws M3x8mm.</li> </ul>	<p><b>Landing Gear Silver [H0725-S]</b></p> <ul style="list-style-type: none"> <li>- 1 x Landing Gear Silver.</li> <li>- 4 x Head Cap Screw M3x12.</li> <li>- 4 x Aluminum Washer M3.</li> </ul>	<p><b>Blades Grip Arm Black Matte HF3C [H0817BM-S]</b></p> <ul style="list-style-type: none"> <li>- 2 x Blade Grip Arm BM.</li> <li>- 2 x Head Cap Screw M4x10.</li> <li>- 2 x Uniball M3x4 Ø5 H3.5.</li> </ul>		
<p><b>Canopy Ennio Graber Edition [H0821-S]</b></p> <ul style="list-style-type: none"> <li>- 1 x Canopy Ennio Graber Edition.</li> <li>- 2 x Canopy Grommet.</li> <li>- 1 x Canopy Mousse.</li> <li>- 3 x Canopy Edge Protection.</li> </ul>	<p><b>Tail Boom Ennio Graber Edition [H0822-S]</b></p> <ul style="list-style-type: none"> <li>- 1 x Tail Boom Ennio Graber Edition.</li> <li>- 2 x Locking Element Tails.</li> <li>- 1 x Set Screws M3 x 20mm.</li> <li>- 2 x Washers 3.1 x 12 x 1.8mm.</li> <li>- 4 x Metric Hex Nylon Nuts M3.</li> <li>- 2 x Head Cap Screws M3x12mm.</li> <li>- 2 x Nylon Screw M8x20mm.</li> <li>- 1 x Flat Head Cap Screws M3x8mm.</li> <li>- 2 x Boom spacers.</li> <li>- 2 x Double-Sided Tapes.</li> </ul>		<p><b>Composite Tail Fin Red [H0823-S]</b></p> <ul style="list-style-type: none"> <li>- 1 x Composite Tail Fin Red.</li> </ul>	<p><b>Carbon Fiber Main Frame [H0824-S]</b></p> <ul style="list-style-type: none"> <li>- 1 x Main Frame.</li> </ul>

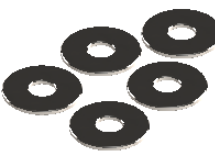

<p>[HC002-S]</p>  <p>- 8 x Socket Head Cap Screws M2x5mm.</p>	<p>[HC004-S]</p>  <p>- 8 x Socket Head Cap Screws M2x6mm.</p>	<p>[HC008-S]</p>  <p>- 8 x Socket Head Cap Screws M2x8mm.</p>	<p>[HC010-S]</p>  <p>- 8 x Socket Head Cap Screws M2x10mm.</p>	<p>[HC018-S]</p>  <p>- 8 x Socket Head Cap Screws M2.5x6mm.</p>	<p>[HC020-S]</p>  <p>- 8 x Socket Head Cap Screws M2.5x8mm.</p>
<p>[HC026-S]</p>  <p>- 8 x Socket Head Cap Screw M2.5x12mm.</p>	<p>[HC033-S]</p>  <p>- 4 x Socket Head Shoulder M2.5x19mm. - 4 x Metrix Hex Nylon Nut M2.5.</p>	<p>[HC038-S]</p>  <p>- 8 x Button Head Cap Screws M3x4mm.</p>	<p>[HC044-S]</p>  <p>- 8 x Socket Head Cap Screws M3x6mm.</p>	<p>[HC050-S]</p>  <p>- 8 x Socket Head Cap Screws M3x8mm.</p>	<p>[HC056-S]</p>  <p>- 8 x Socket Head Cap Screws M3x10mm.</p>
<p>[HC062-S]</p>  <p>- 8 x Socket Head Cap Screws M3x12mm.</p>	<p>[HC068-S]</p>  <p>- 8 x Socket Head Cap Screws M3x16mm.</p>	<p>[HC079-S]</p>  <p>- 8 x Socket Head Cap Shoulder M3x18mm.</p>	<p>[HC086-S]</p>  <p>- 8 x Socket Head Cap Screws M3x22mm.</p>	<p>[HC091-S]</p>  <p>- 4 x Socket Head Shoulder M3x40mm.</p>	<p>[HC096-S]</p>  <p>- 8 x Button Head Cap Screws M4x6mm.</p>
<p>[HC098-S]</p>  <p>- 8 x Button Head Cap Screws M4x8mm.</p>	<p>[HC100-S]</p>  <p>- 8 x Button Head Cap Screws M4x10mm.</p>	<p>[HC102-S]</p>  <p>- 8 x Socket Head Cap Screws M4x10mm.</p>	<p>[HC104-S]</p>  <p>- 8 x Socket Head Cap Screws M4x22mm.</p>	<p>[HC116-S]</p>  <p>- 2 x Socket Head Cap Shoulder M5x35mm. - 2 x Metrix Hex Nut M5.</p>	
<p>[HC122-S]</p>  <p>- 8 x Button Head Cap Screws M6x10mm.</p>	<p>[HC128-S]</p>  <p>- 8 x Flat Head Cap Screws M2.5x5mm.</p>	<p>[HC134-S]</p>  <p>- 8 x Flat Head Cap Screws M3x8mm.</p>	<p>[HC140-S]</p>  <p>- 8 x Cup Point Set Screws M2.5x20mm.</p>	<p>[HC150-S]</p>  <p>- 8 x Cup Point Set Screws M3x20mm.</p>	<p>[HC152-S]</p>  <p>- 8 x Cup Point Set Screws M4x4mm.</p>
<p>[HC153-S]</p>  <p>- 8 x Cup Point Set Screws M4x6mm.</p>	<p>[HC170-S]</p>  <p>- 10 x Washer Ø2,2xØ5x0,3mm.</p>	<p>[HC176-S]</p>  <p>- 5 x Washer Ø3xØ4x0,5mm.</p>	<p>[HC181-S]</p>  <p>- 10 x Washer Ø3xØ7x1mm.</p>	<p>[HC188-S]</p>  <p>- 5 x Washer Ø5.3xØ15x1mm.</p>	<p>[HC194-S]</p>  <p>- 8 x Washer Ø6.3xØ15x1mm.</p>

<p>[HC200-S]</p>  <p>- 10 x Metric Hex Nylon Nuts M2,5H3,5.</p>	<p>[HC206-S]</p>  <p>- 10 x Metric Hex Nylon Nuts M3H4.</p>	<p>[HC212-S]</p>  <p>- 10 x Metric Hex Nylon Nuts M4H5.</p>	<p>[HC218-S]</p>  <p>- 5 x Metric Hex Nylon Nuts M5H4.5.</p>	<p>[HC230-S]</p>  <p>- 5 x Shims Ø10xØ16x1mm.</p>
<p>[HC232-S]</p>  <p>- 5 x Shims Ø10xØ16x0.2mm.</p>	<p>[HC451-S]</p>  <p>- 1 x Carbon Rod Ø4xØ2,5x851mm. - 2 x Plastic Ball Linkage. - 2 x Thread Rod M2.5x40mm.</p>	<p>[HC242-S]</p>  <p>- 3 X Thread Rods M2.5x40mm.</p>	<p>[HC325-S]</p>  <p>- 1 x Main Belt.</p>	<p>[HC308-S]</p>  <p>- 1 x Motor Belt 240-3MGT 13mm.</p>
<p>[HC315-S]</p>  <p>- 2 x Spring 5,8/df 0,3/LL 9. - 1 x Spring 8 /df 0,5 / LL 8. - 2 x Spring 3 /df 5 / LL 12.</p>	<p>[HC400-S]</p>  <p>- 4 x Flanged Bearings Ø 2.5x Ø 6x2.6mm.</p>	<p>[HC402-S]</p>  <p>- 4 x Flanged Bearings Ø 3x Ø 7x3mm.</p>	<p>[HC410-S]</p>  <p>- 4 x Flanged Bearings Ø 5x Ø 9x3mm.</p>	<p>[HC411-S]</p>  <p>- 4 x Bearings Ø 5x Ø 10x4mm.</p>
<p>[HC414-S]</p>  <p>- 2 x Flanged Bearings Ø 6x Ø 13x4mm.</p>	<p>[HC418-S]</p>  <p>- 2 x Flanged Bearings Ø 8x Ø 12x3.5mm.</p>	<p>[HC420-S]</p>  <p>- 2 x Bearings Ø 10x Ø 15x4mm.</p>	<p>[HC422-S]</p>  <p>- 4 x Bearings Ø 10x Ø 19x5mm.</p>	<p>[HC426-S]</p>  <p>- 2 x Bearings Ø 12x Ø 24x6mm.</p>
<p>[HC430-S]</p>  <p>- 2 x Rad Bearings Ø 30x Ø 37x4mm.</p>	<p>[HC435-S]</p>  <p>- 2 x Thrust Bearings Ø 5x Ø 10x4mm.</p>	<p>[HC438-S]</p>  <p>- 2 x Thrust Bearings Ø 10x Ø 18x5.5mm.</p>	<p>[HC442-S]</p>  <p>- 1 x One Way Bearings Ø 10x Ø 14x12mm.</p>	<p>[HA016-S]</p>  <p>- 1 x Wrench Tool M8,M6.</p>
<p>[HA026-S]</p>  <p>- 8 x Heat Shrink - Clear.</p>	<p>[HA001-S]</p>  <p>- 1 x Blade Holder.</p>	<p>[HA112-S]</p>  <p>- 1 x Rubber Canopy Edge Protection.</p>	<p>[730TB-S]</p>  <p>- 2 x Main Blade.</p>	<p>[115TB &gt;&gt; SG725] [105TB &gt;&gt; SG726]</p>  <p>- 2 x Tail Blade.</p>

## UPGRADES and ACCESSORIES

### Damper

[H0482-70-S]  
70° Shore

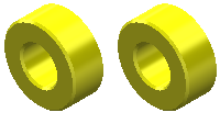

[H0482-90-S]  
90° Shore

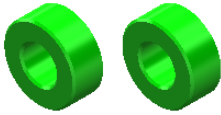

### Tail Pulley

[H0102-S] ( 27T )

[H0103-S] ( 26T )



[H0154-S] ( 25T )

### Delrin CNC Precision Antirotation Guide (H0458-S)



- 1 x Carbon Fiber Antirotation Guide Support.
- 1 x CNC Plastic Guide.
- 1 x Socket Head Cap Screw M2.5x10.
- 1 x Nylon Nut M2.5.
- 1 x Socket Head Cap Screw M3x8.
- 1 x Aluminum M3 Washer.

### Quick release Canopy Knob (H0714-S)



- 2 x Quick Release Canopy Knob.

### SAB HELIDIVISION Futaba Servo Horn [HA050-S]



- 4 x Plastic Servo Horn.

### SAB HELIDIVISION JR Servo Horn [HA051-S]



- 4 x JR Servo Horn.

### Short Main Shaft [H0122-S] + [H0459-S] + [HC140-S]



### Carbon Fuselage ready to paint [H0732-S]



- 1 x Canopy Carbon Ready to Paint.
- 1 x Boom Carbon Ready to Paint.
- 1 x Tail Fin Carbon Ready to Paint.
- Hardwares for Boom and Canopy.

### SAB HELIDIVISION Team Cap - Black [HM003-S]



- 1 x Team Cap - Black.

### SAB HELI DIVISION New Black T-shirt [HM025-S-M-L-XL-XXL]



- SAB HELI DIVISION New Black T-shirt.

### SAB HELI DIVISION Black Polo Shirt [HM027-S-M-L-XL-XXL]



- SAB HELI DIVISION Black Polo Shirt.

### SAB HELI DIVISION Black Hoodies [HM029-S-M-L-XL-XXL]



- SAB HELI DIVISION Black Hoodies.

### SAB HELI DIVISION Neck Strap [HM034-S]



- 1 x Neck Strap.

### SAB Transmitter Case [HM055-S]



- 1 x Transmitter Case.

### Sab Goblin 630/700/770/ Urukay Competition/Speed Carry Bag [HM060-S]



- 1 x Carry Bag.

*The new Goblin Urukay Carbon with its important changes, improves an already successful helicopter and makes it the pinnacle for competitions.*

*The differences and versatility of the Urukay Carbon allow you to experience a new dimension of model helicopter flight.*

*E. Graber*  
Ennio Graber

F3C WORLD CHAMPION  
F3C EUROPEAN CHAMPION



[WWW.GOBLIN-HELICOPTER.COM](http://WWW.GOBLIN-HELICOPTER.COM)

[WWW.SABITALY.IT](http://WWW.SABITALY.IT)

SAB HELI DIVISION