



SAB HELI DIVISION 2016

HELI-SHOP.COM

GOBLIN-HELICOPTER.EU



- Carefully check your model before each flight to ensure it is airworthy.
- Consider flying only in areas dedicated to the use of model helicopters.
- Check and inspect the flying area to ensure it is clear of people obstacles.
- Rotor blades can rotate at very high speeds! Be aware of the danger they pose.
- Always keep the model at a safe distance from other pilots and spectators.
- Avoid maneuvers with trajectories towards a crowd.
- Always maintain a safe distance from the model.



- Um die Flugtüchtigkeit zu erhalten, prüfen Sie Ihr Modell vor und nach jedem Flug.
- Fliegen oder betreiben Sie Ihren Helikopter nur auf Flugplätzen die für den Betrieb von Modellhelikoptern vorgesehen und amtlich genehmigt sind.
- Befolgen Sie die Sicherheitsbestimmungen Ihres Flugplatzbetreibers.
- Achten Sie darauf dass sich weder andere Personen, Zuschauer oder sonstige Hindernisse auf dem Flugfeld bzw. vor dem Sicherheitsnetz befinden.
- Zuschauer und andere Personen müssen sich stets hinter einem dafür vorgesehenen Sicherheitsnetz befinden.
- Halten Sie stets sicheren Abstand zu Ihrem Modell. (zumindest 20m)
- Sorgen Sie dafür dass allfällige Helfer zumindest 30m Abstand einhalten. Helfer müssen sich zudem einer Unterweisung des Piloten beugen.
- Achten Sie bei allen Flugmanövern darauf, dass sich das Modell im Falle eines Kontrollverlustes von den Zuschauern weg bewegt.



INTRODUCTION



SAB blickt auf über 20 Jahre Erfahrung in der Produktion von Rotorblättern für Modellhelikoptern zurück. Die Bandbreite reicht dabei von Blättern der 250er Größe bis hin zu UAV Blätter für bis zu 4 Meter Rotordurchmesser.

Die „Goblin Idee“ begann im Jahre 2011 mit dem ersten Goblin 700. Seither entstand aus einer natürlichen Evolution heraus die volle Bandbreite aller SAB Helis. Die Neuheiten 2016 halten Sie gerade in Ihren Händen. **SAB hat den Modellheli revolutioniert.**

| | |
|-------------------------------------|---------|
| Goblin Nitro | page 4 |
| Goblin Thunder | page 6 |
| Goblin 380, Goblin 380 KSE | page 8 |
| Goblin 500 Sport, Goblin 500 Carbon | page 10 |
| Goblin 570 | page 12 |
| Goblin 630-700-770 | page 13 |
| Goblin 570 KSE | page 14 |
| Goblin 700 KSE | page 15 |
| Goblin Speed | page 16 |
| Goblin Urukay | page 17 |
| Rotor head | page 18 |
| Apparel/ Accessories | page 19 |
| Blades | page 20 |
| Event/ Team pilots | page 24 |
| All Kits | page 26 |
| Spare parts | page 28 |

GOBLIN BLACK NITRO

NEVER SO FAST

Der Antrieb mit Glühzündermotor oder auch Nitro Motor genannt, eröffnet völlig neue Dimensionen für den Goblin.

Eine optimale Schwerpunktlage in Verbindung mit dem optimierten 650mm Rotorsystem stehen für höchste Agilität und Performance. Zusätzlich wurde auf optimale Zugänglichkeit und maximale Wartungsfreundlichkeit geachtet.

Das SAB Antriebskonzept ermöglicht den Ein- bzw. Ausbau des Motors sowie des Tanks innerhalb weniger Minuten.



GOBLIN BLACK NITRO

- * Hauptrotordurchmesser: 1468mm mit 650mm Blätter
- * Abfluggewicht flugfertig: 4700g (Durchschnittswert)
- * Benötigte Servogröße TS: Standard Größe (40mm)
- * Benötigte Servogröße Heck: Standard Größe (40mm)
- * Vorgesehene Motorisierung: 90" bis 120" Glühzünder



Alle Antriebskomponenten wie z.B. Motor, Schalldämpfer, Kupplung, Gebläselüfter etc. bilden eine kompakte Einheit Welche sich durch Lösen von nur vier Schrauben entfernen lässt.



Der korrekte Rundlauf aller Antriebskomponenten steht an erster Stelle. Startmitnehmer, Kupplung und Lüfter sind direkt an die Kurbelwelle angeflanscht. Diese Bauweise garantiert den bestmöglichen Rundlauf.

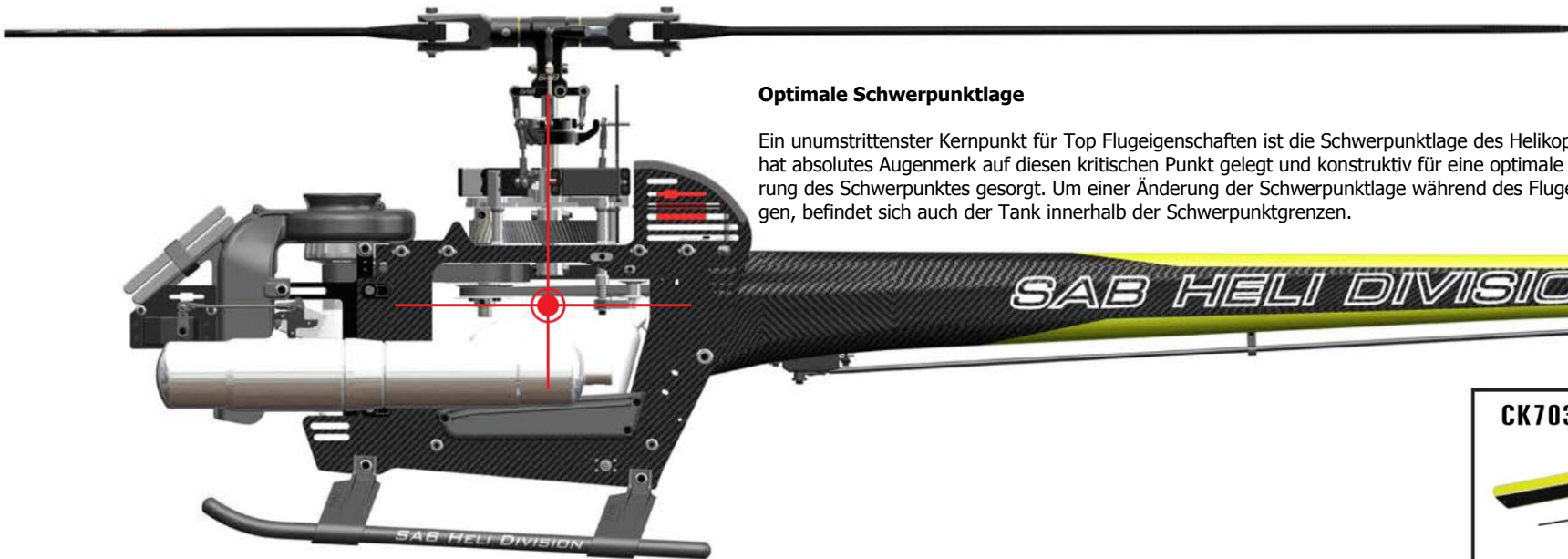
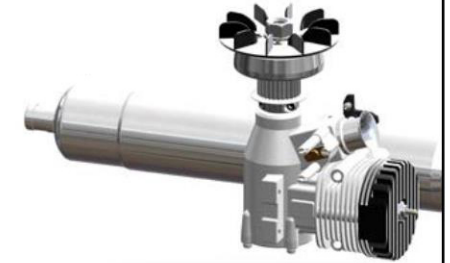

Optimale Schwerpunktlage

Ein unumstrittenster Kernpunkt für Top Flugeigenschaften ist die Schwerpunktlage des Helikopters. SAB hat absolutes Augenmerk auf diesen kritischen Punkt gelegt und konstruktiv für eine optimale Positionierung des Schwerpunktes gesorgt. Um einer Änderung der Schwerpunktlage während des Fluges vorzubeugen, befindet sich auch der Tank innerhalb der Schwerpunktgrenzen.

CK703: 700 Stretch KIT



GOBLIN BLACK THUNDER

ABSOLUTE POWER.

Der Black Thunder bietet den perfekten Mix von Leistung und Eleganz.

Mit Antriebsakkus von 4.200mAh bis 6.000mAh werden sagenhafte Flugleistungen erbracht.

Die SAB Heli Division hat dieses Modell komplett in Carbon erstellt. Dies senkt das Fluggewicht verleiht dem Black Thunder einen eigenständigen, aggressiven Look.



GOBLIN BLACK THUNDER

* Hauptrotordurchmesser: 1468 mm mit 650 mm Blätter

* Abfluggewicht flugfertig: 4900g (Durchschnittswert)

* Benötigte Servogröße TS: Standard Größe (40mm)

* Benötigte Servogröße Heck: Standard Größe (40mm)

* Vorgesehene Motorisierung: 12S—4200mAh, 120A Esc, 560 Kv

Die neue Oberflächen Behandlung: BLACK MATTE



H0696-S: Optional Landing gear



CK703: 700 Stretch KIT



GOBLIN 380



DER KLEINE GROßE!

Für Einsteiger oder Liebhaber des spontanen Fliegens ist der Goblin 380 perfekt! Leicht zu fliegen und leicht zu warten, optimal um jederzeit und fast zu jedem Ort fliegen zu können.

Dank der bequemen Tragetasche ist der Goblin 380 auch leicht überall mitzuführen.

GOBLIN 380

- * Hauptrotordurchmesser: 856 mm mit 380 mm Blätter
- * Abfluggewicht flugfertig: 1400g (Durchschnittswert)
- * Benötigte Servogröße TS: Mikro Größe (23mm)
- * Benötigte Servogröße Heck: Mini Größe (35mm)
- * Vorgesehene Motorisierung: 6S—2000mAh, 80A Esc, 900 Kv

GOBLIN 380 CARRY BAG - HM056



Diese wasserdichten Tragetaschen sind speziell für Goblin 380 Helikopter gemacht, und bietet somit besten Schutz.

Extra Polsterung hält den Heli in einer aufrechten Position und schützt ihn gleichzeitig vor Schäden.

GOBLIN 380 KSE



SUPER POCKET 3D!

Wie der Goblin 380 ist auch die KSE Version ideal für einen spontanen Flug nach Feierabend.

3-Blatt Rotor, Carbon Landegestell und der typische KSE style sind Eigenschaften, die den KSE prägen und einzigartig machen!

GOBLIN 380

- * Hauptrotordurchmesser: 820 mm mit 360 mm Blätter
- * Abfluggewicht flugfertig: 1460g (Durchschnittswert)
- * Benötigte Servogröße TS: Mikro Größe (23mm)
- * Benötigte Servogröße Heck: Mini Größe (35mm)
- * Vorgesehene Motorisierung: 6S—2000mAh, 80A Esc, 900 Kv

GOBLIN 500 SPORT

MIT STIL DURCHSTARTEN

Der Einsteiger der SAB Helidivision. Kompakt im Packmaß, präzise zu fliegen und durch und durch ein vollwertiger Goblin.



GOBLIN 500

- * Hauptrotordurchmesser: 1136 mm mit 500 mm Blätter
- * Abfluggewicht flugfertig: 2600g (Durchschnittswert)
- * Benötigte Servogröße TS: Mini 35mm / oder Standard Größe
- * Benötigte Servogröße Heck: Standard Größe (40mm)
- * Vorgesehene Motorisierung: 6S—4000mAh, 100A Esc, 1200 Kv



Combos mit Antrieb und Servobestückung online

AGRESSIVE OPTIK

Eine Evolution des Goblin 500, im neuen Carbon Look!

Besitzt die gleichen Eigenschaften wie der Goblin 500, jedoch mit einer noch nie gesehenen Eleganz!

GOBLIN 500 SPORT CARBON



GOBLIN 500

- * Hauptrotordurchmesser: 1136 mm mit 500 mm Blätter
- * Abfluggewicht flugfertig: 2600g (Durchschnittswert)
- * Benötigte Servogröße TS: Mini / Standard Größe
- * Benötigte Servogröße Heck: Standard Größe (40mm)
- * Vorgesehene Motorisierung: 6S—4000mAh, 100A Esc, 1200 Kv

GOBLIN 570



DIE PERFEKTE GRÖßE!

Ein optimales Mittelmaß an Größe und Handling.

Eine präzise eingestellte Gewicht/Leistung Rate mit der Möglichkeit 6s als auch 12s zu benutzen. Dies macht den Goblin 570 zum idealen Schritt um in die höheren Klassen des Modellfliegens aufzusteigen.

Spaß in Sport und 3D Flug ist garantiert!

GOBLIN 570

- * Hauptrotordurchmesser: 1278 mm mit 570 mm Blätter
- * Abfluggewicht flugfertig: 3400g (Durchschnittswert)
- * Benötigte Servogröße TS: Standard Größe (40 mm)
- * Benötigte Servogröße Heck: Standard Größe (40mm)
- * Vorgesehene Motorisierung: 6S—5000mAh, 120A Esc, 1100 Kv
12S—3000mAh, 100A Esc, 560 Kv

GOBLIN 630-700-770



GOBLIN 770

- * Hauptrotordurchmesser: 1728 mm mit 770 mm Blätter
- * Abfluggewicht flugfertig: 5800g (Durchschnittswert)
- * Benötigte Servogröße TS: Standard Größe (40 mm)
- * Benötigte Servogröße Heck: Standard Größe (40mm)
- * Vorgesehene Motorisierung: 14S—5000mAh, 200A Esc, 480 Kv

GOBLIN 700

- * Hauptrotordurchmesser: 1568 mm mit 690 mm Blätter
- * Abfluggewicht flugfertig: 5500g (Durchschnittswert)
- * Benötigte Servogröße TS: Standard Größe (40 mm)
- * Benötigte Servogröße Heck: Standard Größe (40mm)
- * Vorgesehene Motorisierung: 12S—5000mAh, 160A Esc, 520 Kv

DER ERSTE!

Der Ruf der Goblin Serie basiert auf drei wundervollen Maschinen, welche mittlerweile weltweit bekannt sind. Mechanisch optimiert und ästhetisch entworfen, das sind die Eigenschaften der SAB Goblin Serie!

Die Einfachheit der Wartung, robuste Bauweise und beste Agilität sowie ein einzigartiges Design machen diese drei Helikopter zu Legenden.



GOBLIN 570 KSE

SPITZENMÄßIGE LEISTUNG!

Wenn man mit 3-Blatt Konfigurationen Erfahrungen sammeln möchte, ist der Goblin 570 KSE genau richtig! Hohe Leistung und die TOP PERFORMANCE des HPS Rotors zu einem unschlagbaren Preis!



GOBLIN 570 KSE

* Hauptrotordurchmesser: 1228 mm mit 540 mm Blätter

* Abfluggewicht flugfertig: 3500g (Durchschnittswert)

* Benötigte Servogröße TS: Standard Größe (40 mm)

* Benötigte Servogröße Heck: Standard Größe (40mm)

* Vorgesehene Motorisierung: 6S—5000mAh, 120A Esc, 1100 Kv
12S—3000mAh, 100A Esc, 560 Kv

GOBLIN 700 KSE

DIE NUMMER EINS IM 3D FLUG!

Kyle Stacy, Gewinner von mehreren Weltmeisterschaften, verbesserte diesen agilen 3-Blatt Helikopter, basierend auf seiner Erfahrung als Modellflieger.

Es ist mit Sicherheit die beste 3D Maschine, ruhig, präzise und leistungsstark mit einem eleganten Design.



Kyle Stacy and G700 KSE

- Erster Platz im 3D Cup 2015
- Erster Platz im „One“ Wettbewerb 2015



GOBLIN 700 KSE

- * Hauptrotordurchmesser: 1578 mm mit 690 mm Blätter
- * Abfluggewicht flugfertig: 5800g (Durchschnittswert)
- * Benötigte Servogröße TS: Standard Größe (40 mm)
- * Benötigte Servogröße Heck: Standard Größe (40mm)
- * Vorgesehene Motorisierung: 12S—5000mAh, 160A Esc, 520 Kv

GOBLIN SPEED CARBON



SPEED & 3D

Die ideale Maschine um Höchstgeschwindigkeiten zu erreichen ohne die Möglichkeit des 3D und Sport Fluges aufzugeben.

Das im Kit integrierte Upgrade Equipment ermöglicht den Einbau der leistungsfähigsten Triebwerke.

GOBLIN SPEED CARBON

- * Hauptrotordurchmesser: 1626 mm mit 720 mm Blätter
- * Abfluggewicht flugfertig: 6000g (Durchschnittswert)
- * Benötigte Servogröße TS: Standard Größe (40 mm)
- * Benötigte Servogröße Heck: Standard Größe (40mm)
- * Vorgesehene Motorisierung: 14S—5000mAh, 200A Esc, 480 Kv

GOBLIN URUKAY CARBON

PURE ELEGANZ!

Nicht König sondern Kaiser in Eleganz!

Hohe Flugstabilität und einfache Wartung, Spaß ohne Ende!

Erhältlich in 2-Blatt und 3-Blatt sowie matt Schwarz und Carbon Variationen.

Eine große Anzahl an speziellen Anpassungen machen den Goblin Urukay perfekt für F3C Wettbewerbe. Ennio Graber hat in die vorliegende Konzeption all seine Erfahrung einfließen lassen.



GOBLIN URUKAY CARBON

* Hauptrotordurchmesser: 1688 mm mit 725 mm Blätter

* Abfluggewicht flugfertig: 6000g (Durchschnittswert)

* Benötigte Servogröße TS: Standard Größe (40 mm)

* Benötigte Servogröße Heck: Standard Größe (40mm)

* Vorgesehene Motorisierung: 12S—5000mAh, 160A Esc, 450 Kv

ROTOR HEAD OPTION

DER KOPF NACH DEM DU SUCHST!

Noch nie war es so einfach einen 2-Blatt Goblin in eine 3-Blatt Version zu verwandeln!

Dank einer Vielzahl an Optionen kann man das Gefühl des 3-Blatt Fluges hautnah miterleben... ruhig, agil und elegant.

H0430-K

Rotor-Kopf 3-Blatt [Silber]

Hauptblätter Länge: von 630mm bis 750mm

H0430 BL-K

Rotor-Kopf 3-Blatt [Schwarz]

Hauptblätter Länge: von 630mm bis 750mm

H0489-K (Goblin 500)

Rotor-Kopf 3-Blatt [Silber]

Enthält Hauptblätter 465mm

H0490-K (Goblin 570)

Rotor-Kopf 3-Blatt [Silber]

Enthält Hauptblätter 540mm

H0640-K (Goblin 380)

Rotor-Kopf 3-Blatt [Silber]

Enthält Hauptblätter 360mm

H0726-K



Rotor-Kopf 2-Blatt [Mattschwarz]
Hauptblätter Länge: 630 bis 750mm

H0727-K



Rotor-Kopf 3-Blatt [Mattschwarz]
Hauptblätter Länge: 630 bis 750mm



APPAREL & ACCESSORIES



HM029: HOODIE BLACK SAB



HM027: POLO BLACK SAB



HM025: TSHIRT BLACK SAB



HM031: T-SHIRT GOBLIN GIRL



HM032: HOODIE GOBLIN GIRL

HM001: WHITE CAP

HM002: BLACK CAP

HM004: GOBLIN GIRL CAP



HM003: TEAM CAP

HM060: Carry bag big size

(For G630-G700-G770
GSPEED-GURUKAY)



HM059: Carry bag medium size

(For G500-G570)

HM056: Carry bag small size

(For G380)



HM048: HEX TOOL 1.5



HM049: HEX TOOL 2.0



HM050: HEX TOOL 2.5



HM051: HEX TOOL 3.0



HM053: TOOLS KIT

(HEX TOOL 1.5; 2.0; 2.5; 3.0 + TOOLS CASE)



HM055: TRANSMITTER CASE



HM034: NECKSTRAPS



HM041: TOWEL



The latest “Blade Storm” by SAB !

VARIABLES PROFIL

ANGEPASSTE-VARIABLE BLATTTIEFE

NEUES DESIGN

DIES SIND DIE EIGENSCHAFTEN DER NEUEN SAB BLATT GENERATION.



SAB Thunderbolt Main Blades

Stabilität

Das variable Profil verleiht dem Helikopter überragende Stabilität ohne die Beweglichkeit des Rotors einzubüßen.

Agilität

Der spezielle Profilverlauf macht Thunderbolt Blades im Vergleich zum Vorgänger Typ um bis zu 20% effizienter. Die Stahl Eigenschaften konnten merklich verbessert werden. Der laminare Verlauf der Strömung macht sich in allen Fluglagen und Situationen positiv bemerkbar.

Effizienz

Die Blatttiefe variiert am Radius des Rotors. Kürzer am Anfang, größer an der Spitze. Dank der Aerodynamik des Rotors bekommt der Heli mehr Schub.

Dies ermöglicht präzisere Manöver.

Sound

SAB hat eine spitz zulaufendes Ende der Rotorblätter entwickelt um den Helikopter ruhiger und den Rotor effizienter zu machen. Ein Exklusives Design.

Italian Design

Das neue Design sieht nicht nur Super aus, sondern hilft auch die Sichtbarkeit des Helis in der Luft zu verbessern. Insbesondere perfekt für niedrig geflogene Manöver.

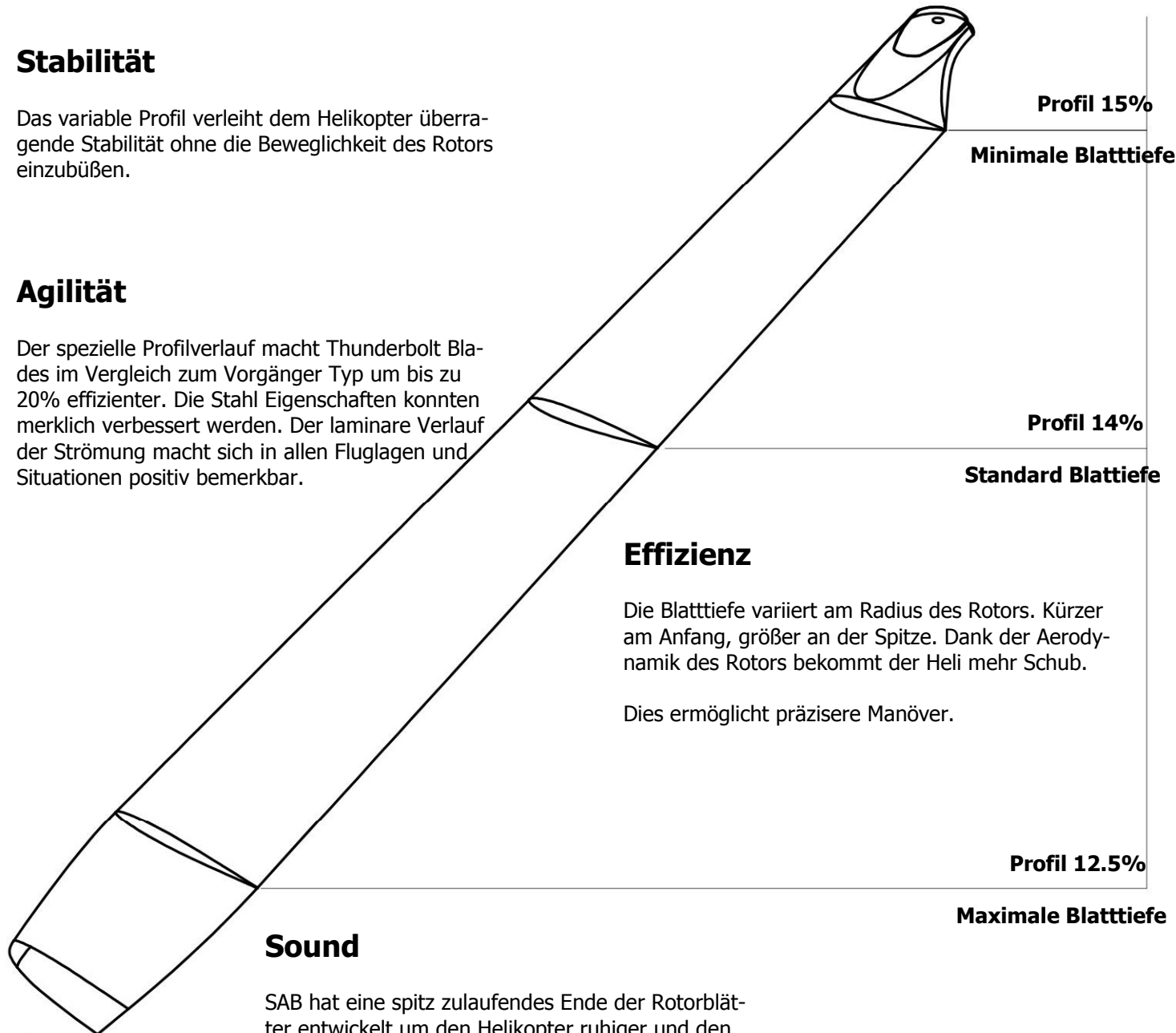

Reaktion

Dank der flexiblen Blatattiefe ermöglichen die Thunderbolt Heckrotorblätter eine bessere Reaktion auf die Befehle des Piloten. Dies bedeutet, dass das Heck sich schneller bewegt und schnellere Manöver ermöglicht sowie eine Erhöhung der Kontrollierbarkeit bietet.

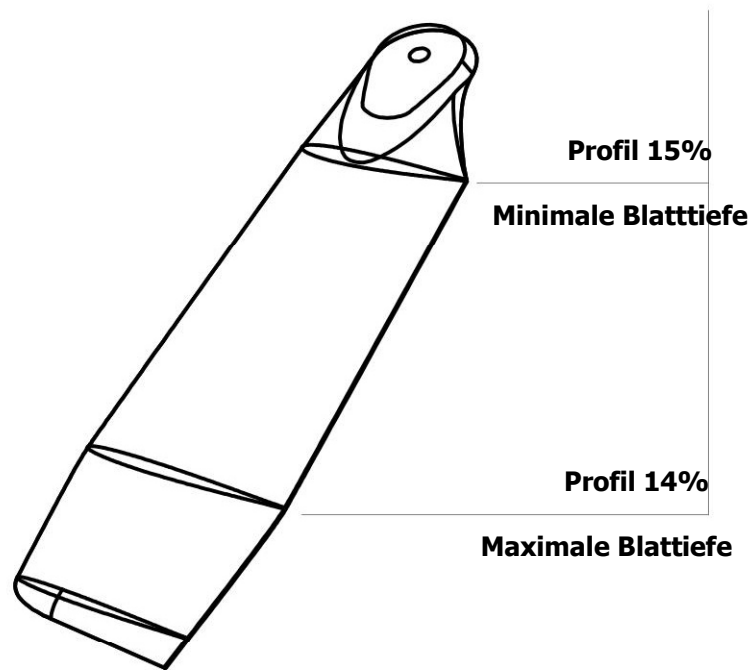

Einzigartig durch Know How

Eine besondere Eigenschaft der Thunderbolt Heckblätter ergibt sich durch die spitz zulaufenden Enden welche das Heck des Helikopters sehr leise werden lassen, aber gleichzeitig die „Griffigkeit“ und das Ansprechverhalten erhöhen.





All over the world
Seit weit über 20 Jahre stattet SAB die Piloten der Weltklasse aus.
Wettbewerbe und Events spielen eine Schlüsselrolle für den Erfolg.





GOBLIN KITS

GOBLIN 380

SG380 SAB GOBLIN 380 RED/BLACK
(with 380mm Black Line Main Blades)



SG381 SAB GOBLIN 380 YELLOW/BLUE
(with 380mm Black Line Main Blades)



SG387 SAB GOBLIN 380 CARBON/GREEN
(with 380mm Black Line Main Blades)



SG382 SAB GOBLIN 380 KYLE STACY EDITION
(With Main and Tail Blades)



GOBLIN 570

SG570 GOBLIN 570 YELLOW/ORANGE
(with blade and tail blade)



SG571 GOBLIN 570 WHITE/SILVER
(with blade and tail blade)



SG572 GOBLIN 570 YELLOW/CARBON
(with blade and tail blade)



SG577 SAB GOBLIN 570 KYLE STACY EDITION
(With Main and Tail Blades)



GOBLIN 500 SPORT

SG507 G500 SPORT WHITE/RED



SG508 G500 SPORT YELLOW/RED



SG509 G500 SPORT WHITE/RED COMBO



SG510 G500 SPORT YELLOW/RED COMBO



SG512 G500 SPORT CARBON



GOBLIN 630

SG632 GOBLIN 630 COMPETITION YELLOW/GREEN
(with blade and tail blade)



SG633 GOBLIN 630 COMPETITION YELLOW/ORANGE
(with blade and tail blade)



SG634 GOBLIN 630 COMPETITION YELLOW/CARBON
(with blade and tail blade)



BLACK

SG651 GOBLIN NITRO
(with blade and tail blade)





SG652 GOBLIN THUNDER
(with blade and tail blade)













All manuals are available on our website

| | | | |
|-------------------|-------|--|--|
| GOBLIN 700 | SG703 | GOBLIN 700 COMPETITION YELLOW/GREEN (with blade and tail blade) |  |
| | SG704 | GOBLIN 700 COMPETITION YELLOW/ORANGE (with blade and tail blade) |  |
| | SG705 | GOBLIN 700 COMPETITION YELLOW/BLUE (with blade and tail blade) |  |
| | SG707 | GOBLIN 700 COMPETITION YELLOW/CARBON (With Main and Tail Blades) |  |
| | SG709 | SAB GOBLIN 700 KYLE STACY EDITION (With Main and Tail Blades) |  |



























| | | | |
|---------------------|-------|--|---|
| GOBLIN SPEED | SG720 | GOBLIN 700 SPEED YELLOW (with SPEED blade and tail Speed blade) |  |
| | SG721 | GOBLIN 700 SPEED ORANGE (with SPEED blade and tail Speed blade)) |  |
| | SG722 | GOBLIN 700 SPEED YELLOW/CARBON (with SPEED blade and tail Speed blade) |  |



| | | | |
|-------------------|-------|--|---|
| GOBLIN 770 | SG772 | GOBLIN 770 COMPETITION YELLOW/GREEN (with blade and tail blade) |  |
| | SG773 | GOBLIN 770 COMPETITION YELLOW/ORANGE (with blade and tail blade) |  |
| | SG774 | GOBLIN 770 COMPETITION YELLOW/BLUE (with blade and tail blade) |  |
| | SG775 | GOBLIN 770 COMPETITION YELLOW/CARBON (With Main and Tail Blades) |  |

| | | | |
|----------------------|-------|---|---|
| GOBLIN URUKAY | SG730 | GOBLIN URUKAY 3 BLADES BLUE/WHITE (W/ 730 BL MAIN BLADES) |  |
| | SG731 | GOBLIN URUKAY 3 BLADES RED/WHITE (W/ 730 BL MAIN BLADES) |  |
| | SG753 | GOBLIN URUKAY 2 BLADES BLUE/WHITE (W/ 750 BL MAIN BLADES) |  |
| | SG754 | GOBLIN URUKAY 2 BLADES RED/WHITE (W/ 750 BL MAIN BLADES) |  |
| | SG732 | GOBLIN URUKAY COMPETITION |  |
| | SG733 | GOBLIN URUKAY CARBON 2 blades |  |
| | SG734 | GOBLIN URUKAY CARBON 3 blades |  |

SPARE PARTS Ip/n from H0001-S to H0061BL-SI

| | | | | | | | | | |
|--|---|---|---|---|---|---|---|--|---|
| H0001-S <small>DISCONTINUED</small> MAIN FRAME (REPLACE BY H0362) |  | H0012-S MAIN GEAR Z 68 |  | H0018-S COLUMN |  | H0038-S SAFETY LOCK TAIL BOOM |  | H0050-S ANTENNA GUIDE |  |
| H0002-S PLAN BATTERIES |  | H0015-18-S PULLEY Z 18 6MM HOLE |  | H0022-S SECONDARY SHAFT |  | H0039-S LANDING GEAR PROTECTION |  | H0051-S TAIL ROTOR HUB |  |
| H0003-S FRAME SPACER |  | H0015-19-S PULLEY Z 19 6MM HOLE |  | <small>DISCONTINUED</small> H0023-S SWASHPLATE (REPLACE BY H0422) |  | H0040-S TAIL SERVO LOCK |  | H0052-S TAIL BLADE GRIP |  |
| H0004-S ESC SUPPORT |  | H0015-20-S PULLEY Z 20 6MM HOLE |  | H0024-S BEARING SUPPORT |  | H0041-S LOCKING ELEMENT TAIL |  | H0053-S TAIL PITCH SLIDER |  |
| H0005-S LANDING GEAR SUPPORT |  | H0015-21-S PULLEY Z 21 6MM HOLE |  | H0026-S DFC CENTER HUB G630 |  | H0042-S BATTERY PROTECTION |  | H0056-S TAIL GRIP LINK |  |
| H0007-S FINISHING WASHER |  | H0015-22-S PULLEY Z 22 6MM HOLE |  | H0027-S DAMPENER |  | H0043-S SPACER FLYBARLESS |  | H0058-S BELL CRANK BASE |  |
| H0008-S CANOPY POSITIONER |  | H0015-23-S PULLEY Z 23 6MM HOLE |  | H0032-S BLADE GRIP ARM DFC |  | H0045-S LINKAGE TAIL SUPPORT |  | H0058BL-S BELL CRANK BASE |  |
| H0009-S MAIN STRUCTURE |  | H0015-24-S PULLEY Z 24 6MM HOLE |  | H0033-S MAIN LINKAGE DFC |  | H0046-S VERTICAL FIN |  | H0059-S BELL CRANK LEVER |  |
| H0010-S SERVOS SUPPORT |  | H0015-26-S PULLEY Z 26 6MM HOLE |  | H0034-S MAIN BLADE GRIP |  | H0047-S TAIL SIDE PLATE |  | H0061-S TAIL CASE SPACER |  |
| H0011-S MOTOR SUPPORT |  | H0017-S SWASHPLATE ANTI ROTATION GUIDE |  | H0036-S CANOPY LOCKING |  | H0048-S TAIL ROTOR SHAFT |  | H0061BL-S TAIL CASE SPACER BLACK |  |

[p/n from H0062-S to H0135-S] SPARE PARTS

| | | | | | | | | | | | | | | |
|---------|--------------------------------|---|--------------------------------|--|---|--------------------------------|--|---|--------------------------------|-------------------------------------|---|------------|----------------------------------|---|
| H0062-S | SPACER Ø7 X Ø9 X 0,5 |  | H0079-S | SPINDLE |  | DISCONTINUED H0099-S | TAIL BOOM GOBLIN 700 (REPLACE BY H0355) |  | DISCONTINUED H0116-S | LANDING GEAR RED |  | H0126-22-S | PULLEY Z 22 8MM HOLE |  |
| H0063-S | UNIBALL GOBLIN M3X4 Ø5 H18 |  | H0080-S | DFC CENTER HUB G700 |  | DISCONTINUED H0100-S | CANOPY GOBLIN 700 (REPLACE BY H0365) |  | H0117-S | VERTICAL FIN RED |  | H0126-23-S | PULLEY Z 23 8MM HOLE |  |
| H0064-S | UNIBALL GOBLIN M2 Ø5 H3,5 |  | H0082-S | BOOM SPACER |  | H0101-S | PULLEY Z 37 (WITH SCREWS) |  | DISCONTINUED H0118-S | TAIL BOOM GOBLIN 700 RED |  | H0126-24-S | PULLEY Z 24 8MM HOLE |  |
| H0065-S | UNIBALL GOBLIN M3X4 Ø5 H3,5 |  | H0085-S | CENTER BLADE GRIP ARM |  | H0102-S | TAIL PULLEY Z27 (WITH SCREWS) |  | DISCONTINUED H0119-S | CANOPY ORANGE (REPLACE BY H0364) |  | H0127-S | LONG MAIN SHAFT |  |
| H0066-S | PLASTIC BALL GOBLIN LINK |  | H0086-S | BLADE GRIP |  | H0103-S | TAIL PULLEY Z26 (WITH SCREWS) |  | H0121-S | LOCKING COLLAR M4 |  | H0130-S | HPS CENTER HUB G630 |  |
| H0070-S | BELT TENSIONER SUPPORT |  | H0087-S | BLADE GRIP ARM |  | H0104-S | PULLEY Z 60 |  | H0122-S | SHAFT M4 |  | H0131-S | BLADE GRIP ARM HPS 630 |  |
| H0073-S | RX BATTERY SUPPORT |  | H0088-S | CARBON FIBER ESC MOUNT |  | DISCONTINUED H0105-S | LANDING GEAR YELLOW (REPLACE BY H0106) |  | H0125-S | STEEL PINION Z 20 |  | H0130BM-S | CENTER HUB BLACK MATT 650 |  |
| H0074-S | LANDING GEAR STRUTS |  | DISCONTINUED H0092-S | TAIL BOOM GOBLIN 630 (REPLACE BY H0363) |  | H0106-S | LOW PROFILE LANDING GEAR YELLOW |  | H0126-19-S | PULLEY Z 19 8MM HOLE |  | H0131BM-S | BLADE GRIP ARM BLACK MATT 650 |  |
| H0075-S | SERVO SPACER |  | DISCONTINUED H0095-S | CANOPY GOBLIN 630 (REPLACE BY H0364) |  | H0110-S | BUSH 10x13x1 |  | H0126-20-S | PULLEY Z 20 8MM HOLE |  | H0132-S | RADIUS ARM |  |
| H0078-S | WASHER Ø3,1 X Ø15 X 1,5 |  | H0097-S | SPINDLE 630 |  | DISCONTINUED H0115-S | CANOPY RED |  | H0126-21-S | PULLEY Z 21 8MM HOLE |  | H0135-S | HUB HPS GOBLIN 700/770 |  |

SPARE PARTS (p/n from H0136-S to H0204-S)

| | | | | | | | | | | | | | | |
|--------------------------------|---|---|-----------|------------------------|---|---------|---------------------------------|---|------------|---------------------------------|---|--------------------------------|------------------------------------|---|
| H0136-S | BLADE GRIP ARM HPS 700/770 |  | H0149-S | BATTERY TRAY |  | H0159-S | CANOPY POSITIONERS |  | H0171-S | ONE WAY DOUBLE BEARIN PULLEY |  | H0175-24-S | PULLEY Z 24 6/8 MM HOLE |  |
| H0139-S | BLADE BUSHING Ø5 X Ø6 X 12 |  | H0150-S | STOP BATTERY TRAY |  | H0160-K | HPS KIT 700 |  | H0172-S | LOW FRONT TAIL PULLEY |  | H0175-25-S | PULLEY Z 25 6/8 MM HOLE |  |
| H0140-S | BLADES SPACER |  | H0152-S | ANTIROTATION GUIDE 770 |  | H0161-K | HPS KIT 630 |  | H0173-S | TAIL SERVOS SPACER |  | H0182-S | BLADE GRIP |  |
| H0141-S | CENTER BLADE GRIP ARM STEEL |  | H0153-S | ESC SUPPORT |  | H0162-S | LANDING GEAR LOW PROFILE RED |  | H0174-S | BELT TENSIONER BIG BELT |  | H0182BL-S | BLADE GRIP BLACK |  |
| H0142-S | MOTOR MOUNT 3° BEARING |  | H0154-S | TAIL PULLEY 24T |  | H0163-S | BOOM 770 RED |  | H0175-18-S | PULLEY Z 18 6/8 MM HOLE |  | H0183-S | BLADE GRIP ARM |  |
| H0143-S | 6MM THIRD BEARING SUPPORT |  | H0154BL-S | TAIL PULLEY 24T Black |  | H0164-S | CANOPY 770 RED |  | H0175-19-S | PULLEY Z 19 6/8 MM HOLE |  | H0183BL-S | BLADE GRIP ARM BLACK |  |
| H0144-S | TECNO DAMPENER |  | H0155-S | TAIL PULLEY 25T |  | H0165-S | ESC HEATSINK (UPGRADE) |  | H0175-20-S | PULLEY Z 20 6/8 MM HOLE |  | DISCONTINUED H0201-S | SWASHPLATE (REPLACE BY H0477-S) |  |
| H0145-S | FRAME 770 |  | H0156-S | PINION Z19 M3 |  | H0169-S | BATTERY TRAY KIT |  | H0175-21-S | PULLEY Z 21 6/8 MM HOLE |  | H0202-S | BLADE GRIP |  |
| DISCONTINUED H0147-S | BOOM 770 YELLOW (REPLACE BY H0380) |  | H0157-S | SECONDARY SHAFT M3 |  | H0170-S | LINKAGE HPS |  | H0175-22-S | PULLEY Z 22 6/8 MM HOLE |  | H0203-S | BLADE GRIP ARM |  |
| DISCONTINUED H0148-S | CANOPY 770 YELLOW / BLUE (REPLACE BY H0381) |  | H0158-S | BLADES SPACER |  | H0171-K | BIG BELT KIT UPGRADE 770 |  | H0175-23-S | PULLEY Z 23 6/8 MM HOLE |  | H0204-S | RADIUS ARM HPS |  |

[p/n from H0205-S to H0260-S] SPARE PARTS

| | | | | | | | | | | | | | | |
|---------|--------------------|---|------------|--------------|---|---------|--------------------|---|---------|---------------------|---|---------|-------------------------|---|
| H0205-S | RADIUS PLASTIC ARM |  | H0215-16-S | PULLEY Z 16 |  | H0217-S | CANOPY POSITIONER |  | H0230-S | PULLEY Z 21 |  | H0244-S | ANTIROTATION GUIDE G500 |  |
| H0206-S | HUB |  | H0215-17-S | PULLEY Z 17 |  | H0218-S | PULLEY Z 28 |  | H0233-S | TAIL PITCH SLIDER |  | H0245-S | SERVO SUPPORT |  |
| H0207-S | BEARING SUPPORT |  | H0215-18-S | PULLEY Z 18 |  | H0220-S | TAIL SPINDLE |  | H0234-S | BELL CRANK LEVER |  | H0248-S | CANOPY LOCKING |  |
| H0208-S | SERVO SUPPORT |  | H0215-19-S | PULLEY Z 19 |  | H0221-S | SECONDARY SHAFT |  | H0236-S | TAIL BLADE GRIP |  | H0249-S | LOCKING ELEMENT TAIL |  |
| H0209-S | MAIN GEAR |  | H0215-20-S | PULLEY Z 20 |  | H0222-S | MAIN SHAFT |  | H0237-S | LINKAGE HPS |  | H0251-S | SERVO LOCK |  |
| H0210-S | PINION Z18 |  | H0215-21-S | PULLEY Z 21 |  | H0223-S | SPACER MAIN SHAFT |  | H0239-S | SPACER 54 MM |  | H0252-S | BATTERY TRAY |  |
| H0211-S | MOTOR SUPPORT |  | H0215-22-S | PULLEY Z 22 |  | H0224-S | SENSOR SUPPORT |  | H0240-S | MAIN FRAME |  | H0255-S | FINISHING WASHER |  |
| H0212-S | MAIN STRUCTURE |  | H0215-23-S | PULLEY Z 23 |  | H0225-S | SPACER 8x12,5x05 |  | H0241-S | LANDING GEAR YELLOW |  | H0256-S | BATTERY BLOCK |  |
| H0213-S | SPINDLE |  | H0215-24-S | PULLEY Z 24 |  | H0227-S | TAIL ROTOR SHAFT |  | H0242-S | VERTICAL FIN YELLOW |  | H0258-S | BATTERY SUPPORT DX |  |
| H0214-S | PULLEY Z 48 |  | H0216-S | SPACER 28 MM |  | H0229-S | BELL CRANK SUPPORT |  | H0243-S | TAIL SIDE PLATE |  | H0260-S | CARBON ROD SUPPORT |  |

SPARE PARTS [p/n from H0261-S to H0327BL-S]

| | | | | | | | | | | | | | | |
|---------|---------------------------|---|---------|-----------------------------|---|---------|---------------------------|---|---------|---------------------------------|---|-----------|-------------------------------|---|
| H0261-S | TAIL LINKAGE |  | H0278-S | BOOM YELLOW / BLACK |  | H0294-S | SECONDARY SHAFT |  | H0305-S | TAIL PULLEY 21T |  | H0317-S | MOTOR MOUNT WITH COOLING G500 |  |
| H0262-S | LANDING GEAR SUPPORT |  | H0281-S | VERTICAL FIN RED |  | H0295-S | ONE WAY PULLEY 60t |  | H0306-S | REAR LANDING GEAR MOUNT |  | H0318-S | HEAVY DUTY MAIN GEAR & PINION |  |
| H0263-S | COLUMN |  | H0285-S | LANDING GEAR RED |  | H0296-S | BLOCK NYLON SCREWS |  | H0307-S | FRONT LANDING GEAR MOUNT |  | H0319-S | QUICK RELEASE CANOPY G700 |  |
| H0265-S | SPACER Ø4 X Ø18 X1 |  | H0287-S | SPACER G500 |  | H0297-S | ALLUMINUM TAIL SIDE |  | H0308-S | CARBON SERVO MOUNT |  | H0320-S | STRONG MAIN GEAR G700 |  |
| H0267-S | BLOCK NUT |  | H0288-S | VERTICAL FIN (white/Yellow) |  | H0298-S | TAIL BOOM BLOCK |  | H0309-S | CARBON PARTS ELECTRONIC SUPPORT |  | H0321-S | QUICK RELEASE CANOPY G500 |  |
| H0268-S | CANOPY YELLOW/BLACK |  | H0289-S | TAIL SERVO SUPPORT |  | H0300-S | TAIL BOOM G570 YELLOW |  | H0310-S | TAIL PULLEY 22T |  | H0322-S | MAIN FRAME GOBLIN 500 2 mm |  |
| H0271-S | CANOPY RED/WHITE |  | H0290-S | MAIN FRAME |  | H0301-S | TAIL BOOM G570 WHITE |  | H0311-S | BATTERY TRAY |  | H0324-S | COMPETITION TAIL ROTOR SET |  |
| H0275-S | BOOM WHITE (FIBER GLASS) |  | H0291-S | MOTOR MOUNT |  | H0302-S | CANOPY G570 YELLOW/ORANGE |  | H0312-S | PLASTIC BATTERY MOUNT |  | H0325-S | TAIL ROTOR SHAFT DAMPER |  |
| H0276-S | BOOM WHITE /RED |  | H0292-S | HEAVY DUTY PINION |  | H0303-S | CANOPY G570 WHITE/GREY |  | H0314-S | ALLUMINUM MINI SERVO SUPPORT |  | H0327-S | TAIL BLADE GRIP WITH DAMPER |  |
| H0277-S | BOOM YELLOW (FIBER GLASS) |  | H0293-S | HEAVY DUTY MAIN GEAR |  | H0304-S | FRONT TAIL PULLEY 28T |  | H0316-S | MOTOR MOUNT WITH COOLING G700 |  | H0327BL-S | TAIL BLADE GRIP WITH DAMPER |  |

Ip/n from H0329-S to H0405-S| SPARE PARTS

| | | | | | | | | | | | | | | |
|---------|--------------------------------------|---|---------|------------------------------------|---|---------|--------------------------------------|---|---------|---|---|---------|-----------------------------------|---|
| H0329-S | TAIL SPINDLE 5MM |  | H0352-S | FULL SIZE SERVO CANOPY G500 W/R |  | H0363-S | TAIL BOOM G630 CO YELLOW |  | H0378-S | SPEED CANOPY LOCKING |  | H0389-S | BOOM 500 LIMITED EDITION |  |
| H0330-S | SPACER FOR TAIL ROTOR |  | H0354-S | CF 2MM MAIN FRAME G700 CO (1PC) |  | H0364-S | CANOPY G630 CO YELLOW/ORANGE |  | H0379-S | SAFETY LANDING GEAR GOBLIN SPEED 700 |  | H0390-S | CANOPY G700 LIMITED EDITION |  |
| H0331-S | CANOPY 630-700 YELLOW / BLUE |  | H0355-S | TAIL BOOM G700 CO YELLOW |  | H0365-S | CANOPY G630 CO YELLOW/GREEN |  | H0380-S | TAIL BOOM G770 CO YELLOW |  | H0392-S | SERVO BLOCK |  |
| H0343-S | CANOPY 630-700 YELLOW / BLACK |  | H0356-S | CANOPY G700 CO YELLOW/ORANGE |  | H0366-S | TAIL BOOM G700 SPEED YELLOW |  | H0381-S | CANOPY G770 CO YELLOW/BLUE |  | H0394-S | CARBON ROD SUPPORT |  |
| H0344-S | PLASTIC SUPPORT LANDING GEAR G700 |  | H0357-S | CANOPY G700 CO YELLOW/GREEN |  | H0367-S | CANOPY G700 SPEED YELLOW |  | H0382-S | CANOPY G700 SPEED ORANGE |  | H0397-S | ALUMINUM SERVO SUPPORT |  |
| H0345-S | PLASTIC LANDING GEAR G 700 |  | H0358-S | ALUMINUM TAIL BOOM BLOCK |  | H0368-S | KIT ESC TOP GOBLIN SPEED 700 |  | H0383-S | TAIL BOOM G700 SPEED ORANGE |  | H0398-S | MOTOR MOUNT WITH COOLING G570 |  |
| H0346-S | LINKAGE HPS V2 |  | H0359-S | ALUMINUM TAIL SIDE PLATE |  | H0371-S | VERTICAL FIN GOBLIN SPEED 700 |  | H0384-S | NEW BLADE GRIP + NEW MAIN LINKAGE |  | H0401-S | SWASH ANTIROTATION 570 |  |
| H0347-S | CANOPY 500 YELLOW / BLUE |  | H0360-S | ALUMINUM TAIL CASE SPACER |  | H0373-S | KIT SIDE PLATE GOBLIN SPEED 700 |  | H0385-S | LANDING GEAR G500-570 CARBON PARTS |  | H0402-S | PRECISION PLASTIC BALL LINKAGE |  |
| H0350-S | LANDING GEAR PLASTIC G 500/570 |  | H0361-S | HARD PINION 19T, M3 |  | H0374-S | LANDING GEAR SUPPORT GOBLIN SPEED |  | H0386-S | KIT LANDING GEAR 500-570 |  | H0403-S | PLASTIC BALL LINK M2 |  |
| H0351-S | FULL SIZE SERVO CANOPY G500 Y/B |  | H0362-S | CF 2MM MAIN FRAME G630 CO (1PC) |  | H0375-S | LANDING GEAR GOBLIN SPEED 700 |  | H0388-S | CANOPY G500 LIMITED EDITION |  | H0405-S | CNC MAIN GEAR z68 |  |

SPARE PARTS Ip/n from H0406BL-S to H0493-SI

| | | | | | | | | | | | | | | |
|-----------|---------------------------------|---|-----------|---------------------------------------|---|-----------|-----------------------------------|---|---------|-----------------------------------|---|---------|-------------------------------------|---|
| H0406BL-S | TAIL PITCH SLIDER BLACK |  | H0418-S | 3BLADES STEEL TAIL HUB |  | H0428-K | HPS2 KIT UPGRADE |  | H0444-S | ALUMINUM TAIL SIDE PLATE - URUKAY |  | H0471-S | STEEL SPINDLE SHAFT |  |
| H0407-S | 2 BLADE TAIL PITCH SLIDER |  | H0419-S | 3 BLADES STEEL TAIL SHAFT |  | H0429-S | 3 BLADES TAIL SYSTEM SET |  | H0445-S | CARBON MAIN FRAME (1PC) |  | H0473-S | CENTER HUB 500/570 HPS3 |  |
| H0408-S | DOUBLE TAIL PICTH SLIDER |  | H0420-S | 3 HEAD SWASHPLATE |  | H0429BL-S | 3 BLADES TAIL SYSTEM SET (BLACK) |  | H0446-S | CARBON LANDING GEAR (2PCS) |  | H0474-S | RADIUS ARM |  |
| H0409-S | 3 BLADE TAIL PITCH SLIDER |  | H0420BL-S | 3 HEAD SWASHPLATE BLACK |  | H0430-K | HPS3 KIT UPGRADE |  | H0450-S | ALUMINUM HEAT SINK - URUKAY |  | H0475-S | SWASHPLATE HPS3 500/ 570 |  |
| H0409BL-S | 3 BLADE TAIL PITCH SLIDER BLACK |  | H0421-S | RADIUS ARM SET FOR HPS3 |  | H0430BL-K | HPS3 KIT UPGRADE |  | H0452-S | CARBON TAIL FIN |  | H0477-S | SWASHPLATE HPS 500/ 570 |  |
| H0410-S | HPS3 CENTER HUB |  | H0422-S | NEW SWASHPLATE |  | H0435-S | 3 BLADES STEEL TAIL BUSHING M2 |  | H0454-S | F3C LANDING GEAR |  | H0485-S | PLASTIC LANDING GEAR SUPPORT YELLOW |  |
| H0410BL-S | HPS3 CENTER HUB BLACK |  | H0423-S | CNC MAIN GEAR G500/570 |  | H0436-S | ALUMINUM TAIL SERVOS SUPPORT |  | H0456-S | CANOPY and BOOM URUKAY WHITE |  | H0486-S | DAMPER SET |  |
| H0411-S | HPS2 CENTER HUB |  | H0425-S | DELTRIN TECNO DAMPENER - HPS G500/570 |  | H0437-S | STEEL BALL LINKAGE M3 H5.5 |  | H0458-S | ANTIROTATION GUIDE URUKAY - 770 |  | H0489-K | HPS3 G500 |  |
| H0412-S | NEW SPINDLE SHAFT FOR HPS2/3 |  | H0426-S | NEW DESIGN DAMPNER FOR HPS2/3 |  | H0438-S | CANOPY and BOOM URUKAY RED/WHITE |  | H0459-S | ANTIROTATION GUIDE G630-700-SPEED |  | H0490-K | HPS3 G570 |  |
| H0417-S | TITANIUM MAIN LINKAGE |  | H0426D-S | HARD 3D DAMPNER HPS2/3 |  | H0439-S | CANOPY and BOOM URUKAY BLUE/WHITE |  | H0464-S | BLADES GRIP ARM URK CO |  | H0493-S | MAIN FRAME URK CO |  |

[p/n from H0494-S to H0545-S] SPARE PARTS

| | | | | | | | | | |
|------------|---|---------|---|---------|--|---------|---|---------|--|
| H0494-S | CARBON SIDE PLATE URK CO  | H0502-S | 120T MAIN PULLEY  | H0512-S | TAIL PITCH SLIDER  | H0523-S | ALUMINUM TAIL PLATE  | H0535-S | BOOM ACCESSORIES  |
| H0495-S | TAIL SERVO SUPPORT URK CO  | H0503-S | FRONT TAIL PULLEY  | H0513-S | MAIN BLADE GRIP  | H0524-S | LINKAGE SERVO  | H0536-S | BATTERY TRAY  |
| H0496-S | LANDING GEAR SUPPORT URK CO  | H0504-S | 20T TAIL PULLEY  | H0514-S | CENTER HUB  | H0525-S | PLASTIC RADIUS ARM  | H0537-S | UNIBALL M2 FEMALE  |
| H0497-S | WIRING SUPPORT URK CO  | H0505-S | 21T TAIL PULLEY  | H0516-S | RADIUS ARM  | H0526-S | CROSS TAIL CASE  | H0538-S | UNIBALL M2 MALE  |
| H0501-19-S | MOTOR PULLEY 19T  | H0506-S | WASHPLATE SET  | H0517-S | BLADE GRIP ARM  | H0528-S | PLASTIC LANDING GEAR  | H0539-S | BATTERY BLOCK  |
| H0501-20-S | MOTOR PULLEY 20T  | H0507-S | MAIN SHAFT  | H0518-S | DAMPER KIT MAIN ROTOR  | H0529-S | PLASTIC BATTERY SUPPORT  | H0540-S | TAIL SPACER KIT  |
| H0501-21-S | MOTOR PULLEY 21T  | H0508-S | SPINDLE SHAFT  | H0519-S | MAIN PLATE  | H0530-S | TAIL SERVO SUPPORT  | H0542-S | CANOPY NUT  |
| H0501-22-S | MOTOR PULLEY 22T  | H0509-S | TAIL SHAFT + TAIL HUB  | H0520-S | MOTOR SUPPORT  | H0531-S | MAIN FRAME  | H0543-S | CANOPY KNOB  |
| H0501-23-S | MOTOR PULLEY 23T  | H0510-S | TAIL SPINDLE  | H0521-S | ALUMINUM SERVO SUPPORT  | H0532-S | VERTICAL FIN  | H0544-S | YELLOW/BLUE CANOPY  |
| H0501-24-S | MOTOR PULLEY 24T  | H0511-S | TAIL BLADE GRIP  | H0522-S | MAIN SHAFT SUPPORT  | H0533-S | ANTI-ROTATION GUIDE  | H0545-S | RED/BLACK CANOPY  |

SPARE PARTS [p/n from H0546-S to H0650-S]

| | | | | | | | | | |
|---------|---|---------|---|---------|---|---------|---|---------|--|
| H0546-S | YELLOW BOOM  | H0559-S | G380 CANOPY YELLOW / BLACK  | H0584-S | SWASH LEVELER G380  | H0598-S | DFC LINKAGE  | H0635-S | MAIN STRUTURE 500S  |
| H0547-S | RED BOOM  | H0560-S | G380 CANOPY YELLOW / SPORT  | H0587-S | CANOPY GREEN CARBON G380  | H0600-S | HPS3 SWASHPLATE  | H0636-S | SERVO PLATE 500S  |
| H0548-S | PLASTIC SERVO SUPPORT  | H0561-S | LINKAGE ROD M2  | H0588-S | BOOM GREEN CARBON G380  | H0621-S | CF TAIL FIN 500S  | H0637-S | LANDING GEAR 500S  |
| H0551-S | "QUICK BATTERY CONNECTION KIT (include 3 battery try + charge cable)"  | H0562-S | MAGNET QUICK CANOPY RELEASE  | H0589-S | GREEN STICKERS G380  | H0622-S | CF TAIL BOOM YELLOW 500S  | H0638-S | FRONT SUPPORT 500S  |
| H0552-S | 1 QUICK CONNECTION BATTERY TRAY  | H0564-S | FBL SUPPORT  | H0592-S | CANOPY CHINESE SE  | H0623-S | CF TAIL BOOM WHITE 500S  | H0639-S | LANDING GEAR URK CO  |
| H0553-S | QUICK CONNECTION  | H0565-S | TAIL FIN AND LANDING GEAR STICKERS  | H0593-S | BOOM CHINESE SE  | H0624-S | CANOPY YELLOW/SILVER  | H0640-K | HPS3 G380  |
| H0554-S | PLASTIC TAIL BLADES  | H0568-S | TAIL BELT GUIDE  | H0594-S | TAIL FIN CHINESE SE  | H0625-S | CANOPY WHITE/RED  | H0643-S | ANTI-ROTATION GUIDE  |
| H0555-S | LANDING GEAR LOW PROFILE G380  | H0571-S | ALUMINUM ONE WAY PULLEY  | H0595-S | HPS3 CENTER HUB  | H0627-S | URK CO CANOPY BOOM WHITE/RED  | H0644-S | LANDING GEAR SET G380 KSE  |
| H0557-S | LANDING GEAR CARBON PARTS  | H0572-S | TAIL SERVO SPACER  | H0596-S | SPINDLE SHAFT  | H0630-S | URK CO CANOPY BOOM WHITE  | H0645-S | CF LANDING GEAR G380 KSE  |
| H0558-S | G380 CANOPY YELLOW / ORANGE  | H0574-S | COOLING MOTOR SUPPORT  | H0597-S | BLADE GRIP ARM  | H0634-S | MAIN FRAME 500S  | H0650-S | KST MINI CYCLIC SERVO SUPPORT  |

[p/n from H0652-S to H0721-S] SPARE PARTS

| | | | | | | | | | | | | | | |
|-----------|---------------------------------|---|---------------|----------------------------|---|----------|--------------------------------|---|---------|--------------------------|---|-----------|---------------------------|---|
| H0652-S | LANDING GEAR SET G500/570 |  | H0670-S | CLUTCH |  | H0683-S | MAIN PLATE NITRO |  | H0696-S | LG THUNDER UPGARDE |  | H0708-S | FUEL NIPPLE |  |
| H0653-S | SWASH LEVELER G500/570 |  | H0671BM-S | FAN |  | H0684-S | VERTICAL FIN NITRO/THUNDER |  | H0697-S | LG SKIDS UPGARDE |  | H0709-S | FRONT LG SPACER |  |
| H0654-S | CF LANDING GEAR G500/570 |  | H0672-S | CLUTCH SUPPORT |  | H0685-S | SAB FUEL TANK |  | H0698-S | REAR LGS THUNDER ALU |  | H0710-S | CARBON INSERT M4 |  |
| H0655-S | CARBON TAIL BOOM G500 SPORT USA |  | H0674BM-S | CLUTCH BELL |  | H0686-S | TANK SUPPORT RIGHT |  | H0699-S | LG SKIDS THUNDER |  | H0714-S | QUICK CANOPY RELEASE KNOB |  |
| H0659-S | CANOPY G500 SPORT USA |  | H0675 BM-26-S | PULLEY Z 26 |  | H0686T-S | TANK SUPPORT RIGHT-TRANSPARENT |  | H0700-S | CANOPY NITRO BLACK |  | H0715-S | FUEL STOP |  |
| H0660-S | CANOPY YELLOW CARBON |  | H0675 BM-27-S | PULLEY Z 27 |  | H0688-S | MAIN FRAME |  | H0701-S | CANOPY THUNDER BLACK |  | H0716-S | CARBON INSERT M3 |  |
| H0662-S | FAN CASE |  | H0675 BM-28-S | PULLEY Z 28 |  | H0690-S | CF SUPPORT |  | H0702-S | BOOM NITRO - THUNDER 650 |  | H0718 | 3 WAY VALVOL |  |
| H0665-S | ENGINE MOUNT |  | H0678-S | MOTOR FRAME SPACER |  | H0693-S | REAR LGS UPGRADE ALU |  | H0703-S | BOOM NITRO - THUNDER 700 |  | H0719BM-S | BLADE GRIP |  |
| H0668-A-S | ENGINE YS SHAFT |  | H0679BM-S | BLADE GRIP 650 BLACK MATTE |  | H0694-S | FRONT LGS THUNDER |  | H0705-S | FUEL CLUNK |  | H0720BM-S | HUB PIVOT HEAD |  |
| H0668-B-S | ENGINE OS SHAFT |  | H0682-S | ENGINE SUPPORT SPACER |  | H0695-S | REAR LGS UPGRADE ALU |  | H0707-S | SWASHPLATE LEVELER G700 |  | H0721-S | PIVOT HEAD |  |

SPARE PARTS [p/n to H0725-S, p/n CK, HE, HA]

| | | | | | | | | | | |
|---------|---|---------------|--|---|---|---|---|---|--|---|
| H0722-S | LINKAGE PIVOT HEAD  | p/n CK | HE007 | Mini Cyclic servo KST DS589MG  | HA010-S | CABLE PASS  | HA032 | G380 MAIN BLADES HOLDER  | | |
| H0723-S | CANOPY URUKAY SILVER/ CARBON  | | CK601 | G 630 Old , Conversion Comp. KIT, TAIL  | HE008 | Full Size Tail servo KST DS525MG  | HA012-S | BATTERY ORING  | HA035 | DOUBLE-SIDED TAPE 100x35x1  |
| H0724-S | BOOM URUKAY SILVER/ CARBON  | | CK602 | GOBLIN 630, Conversion KIT, Body  | HE009 | ESC HW100A V3  | HA016-S | WRENCH NUTS M8  | HA036 | BATTERY STRAP  |
| H0725-S | LANDING GEAR URUKAY  | | CK701 | G 700 Old , Conversion Comp. KIT, TAIL  | HE010 | KST DS589MG servo gear set  | HA021-S | CANOPY GROUMET  | HA037 | HPS3 570 FOAM BLADES  |
| H0724-S | Crankshaft Clamp  | | CK702 | GOBLIN 700, Conversion KIT, Body  | HE011 | KST HDS25MG servo gear set  | HA023-S | STRAPS 20x440  | HA038 | ORING 3050 90 shore  |
| | | CK703 | STRETCK KIT 700  | HE012 | HW V3 Programming box  | HA024-S | ORING 3050 60 shore  | HA039 | HPS3 380 FOAM BLADES  | |
| | | CK771 | G 770 Old , Conversion Comp. KIT, TAIL  | p/n HA | | HA025-S | STRAPS 25x320  | HA050 | SAB HELI DIVISION Futaba servo arm  | |
| | | p/n HE | | HA001-S | FOAM BLADE HOLDER  | HA026-S | HEAT SHRINK (8 PCS 350MM)  | HA051 | SAB HELI DIVISION JR servo arm  | |
| | | HE003 | QT-4120-1200KV Motor  | HA006-S | CANOPY MOUSSE  | HA027-S | STRAPS 25x540  | HA052 | SERVO ARM SET G380  | |
| | | HE004 | DS-5001HV/DS-7005HV Servo Gear Set  | HA008-S | CANOPY ORING  | HA031 | HPS3 700 FOAM BLADES HOL  | HA054 | ONE WAY STARTER  | |



[p/n HA and HM] SPARE PARTS

| | | |
|---------------------|--------------------------------------|--|
| HA106-S | CANOPY POSITIONER |  |
| HA111-S | CANOPY GROMMET |  |
| HA112-S | CANOPY EDGE PROTECTION (1M) (21 mm) |  |
| HA114-S | CANOPY EDGE PROTECTION (1M) (2,2 mm) |  |
| HA9xxx-S | MANUAL GOBLIN |  |
| p/n HM | | |
| DISCONTINUED | HM001 | WHITE CAP  |
| | HM002 | BLACK CAP  |
| | HM003 | BLACK CAP SAB  |
| DISCONTINUED | HM021-S | CARRY BAG (REPLACE BY HM060)  |

| | |
|-------------|---|
| HM025-S | TSHIRT BLACK SAB  |
| HM025-M | |
| HM025-L | |
| HM025-XL | |
| HM025-XXL | |
| HM025-XXXL | |
| HM025-XXXXL | |
| HM027-S | POLO BLACK SAB  |
| HM027-M | |
| HM027-L | |
| HM027-XL | |
| HM027-XXL | |
| HM027-XXXL | |
| HM027-XXXXL | |
| HM029-S | HOODIE BLACK SAB  |
| HM029-M | |
| HM029-L | |
| HM029-XL | |
| HM029-XXL | |
| HM029-XXXL | |
| HM029-XXXXL | |

| | | |
|---------------------|---------------------|---|
| HM034 | NECKSTRAPS |  |
| HM035 | DECAL |  |
| DISCONTINUED | HM037 | KEYCHAN  |
| HM038 | GOBLIN STAND |  |
| HM040-F | FLAGS |  |
| HM040-S | FLAGS GROUND SPIKE |  |
| HM040-B | FLAGS POLE-BAG |  |
| HM041 | TOWEL |  |
| HM042 | GOBLIN Decal |  |
| HM043 | SAB Blackline Decal |  |

| | | |
|---------------------|-------|--|
| DISCONTINUED | HM046 | G500/570 Carry Bag (REPLACE BY HM059)  |
| DISCONTINUED | HM047 | Gonlin URUKAY Carry Bag (REPLACE BY HM060)  |
| | HM048 | HEX TOOL 1,5  |
| | HM049 | HEX TOOL 2  |
| | HM050 | HEX TOOL 2,5  |
| | HM051 | HEX TOOL 3  |
| | HM053 | TOLLS CASE  |
| | HM054 | KIT TOOLS, 1,5-2-2,5-3-tolls case  |
| | HM055 | TRANSMITTER CASE  |
| | HM056 | CARRY BAG SMALL SIZE (For G380)  |

| | | |
|-------|--|---|
| HM057 | GOBLIN 380 WALL HANGER |  |
| HM059 | CARRY BAG MEDIUM SIZE (For G500-G570) |  |
| HM060 | CARRY BAG BIG SIZE (For G630-G700 G770-GSPEED GURUKAY) |  |
| | | |
| | | |
| | | |
| | | |
| | | |
| | | |

SPARE PARTS [p/n from HC001-S to HC193-S]

| | |
|---------|----------------------------------|
| HC001-S | BUTTON HEAD CAP M2X4 |
| HC002-S | SOCKET HEAD CAP M2X5 |
| HC004-S | SOCKET HEAD CAP M2X6 |
| HC005-S | BUTTON CAP M2X5 |
| HC008-S | SOCKET HEAD CAP M2X8 |
| HC010-S | SOCKET HEAD CAP M2X10 |
| HC014-S | SOCKET HEAD CAP M2X12 |
| HC018-S | SOCKET HEAD CAP M2,5X6 |
| HC019-S | BUTTON HEAD M2,5 X 6 |
| HC020-S | SOCKET HEAD CAP M2,5X8 |
| HC022-S | SOCKET HEAD CAP M2,5X10 |
| HC026-S | SOCKET HEAD CAP M2,5X12 |
| HC028-S | SOCKET HEAD CAP M2,5X15 SHOULD |
| HC031-S | SHOULDER SOCKET HEAD CAP M2,5X15 |

| | |
|---------|--------------------------------|
| HC032-S | SOCKET HEAD CAP M2,5X18 |
| HC033-S | SOCKET HEAD CAP M2,5X19 SHOULD |
| HC038-S | BUTTON HEAD SOCKET CAP M3X4 |
| HC044-S | SOCKET HEAD CAP M3X6 |
| HC050-S | SOCKET HEAD CAP M3X8 |
| HC056-S | SOCKET HEAD CAP M3X10 |
| HC062-S | SOCKET HEAD CAP M3X12 |
| HC068-S | SOCKET HEAD CAP M3X16 |
| HC074-S | SOCKET HEAD CAP M3X16 SHOULD |
| HC078-S | SOCKET HEAD CAP M3X18 SHOULD |
| HC079-S | SOCKET HEAD CAP M3X18 SHOULD |
| HC080-S | SOCKET HEAD CAP M3X20 |
| HC082-S | SOCKET HEAD CAP M3X20 SHOULD |
| HC083-S | SOCKET HEAD CAP M3X22 SHOULD |

| | |
|---------|------------------------------|
| HC086-S | SOCKET HEAD CAP M3X22 |
| HC090-S | SOCKET HEAD CAP M3X30 |
| HC091-S | SOCKET HEAD CAP M3X40 |
| HC092-S | SOCKET HEAD CAP M3X50 |
| HC094-S | BUTTON HEAD SOCKET CAP M3X6 |
| HC096-S | BUTTON HEAD SOCKET CAP M4X6 |
| HC098-S | BUTTON HEAD SOCKET CAP M4X8 |
| HC100-S | BUTTON HEAD SOCKET CAP M4X10 |
| HC102-S | SOCKET HEAD CAP M4X10 |
| HC104-S | SOCKET HEAD CAP M4X22 |
| HC110-S | SOCKET HEAD CAP M4X25 |
| HC111-S | SOCKET HEAD CAP M4X24 SHOULD |
| HC114-S | SOCKET HEAD CAP M5X30 SHOULD |
| HC116-S | SOCKET HEAD CAP M5X35 SHOULD |

| | |
|---------|------------------------------|
| HC122-S | BUTTON HEAD SOCKET CAP M6X10 |
| HC124-S | SOCKET HEAD SOCKET CAP M6X10 |
| HC128-S | FLAT HEAD SOCKET CAP M2,5X5 |
| HC132-S | FLAT HEAD SOCKET CAP M3X5 |
| HC134-S | FLAT HEAD SOCKET CAP M3X8 |
| HC136-S | SELF TAPPING SCREWS M3X10 |
| HC140-S | CUP POINT SET SCREWS M2,5X20 |
| HC144-S | CUP POINT SET SCREWS M3x6 |
| HC146-S | CUP POINT SET SCREWS M2,5X15 |
| HC148-S | CONE POINT SET SCREWS M3X8 |
| HC149-S | CONE POINT SET SCREWS M3X12 |
| HC150-S | CUP POINT SET SCREWS M3X20 |
| HC152-S | CONE POINT SET SCREWS M4X4 |
| HC153-S | CUP POINT SET SCREWS M4X6 |

| | |
|---------|----------------------------|
| HC154-S | CUP POINT SET SCREWS M4X15 |
| HC155-S | CUP POINT SET SCREWS M4X20 |
| HC156-S | CUP POINT SET SCREWS M4X12 |
| HC158-S | CUP POINT SET SCREWS M5X20 |
| HC164-S | NYLON HEX NUT M8X14 |
| HC165-S | NYLON HEX NUT M8X20 |
| HC170-S | WASHER Ø2,2 X Ø5 X 0,3 |
| HC172-S | WASHER Ø2,5 X Ø4 X 0,3 |
| HC176-S | WASHER Ø3 X Ø4 X 0,5 |
| HC180-S | WASHER Ø3,3 X Ø6 X 0,5 |
| HC181-S | WASHER Ø3,3 X Ø7 X 1 |
| HC184-S | WASHER Ø4,3 X Ø11 X 1 |
| HC188-S | WASHER Ø5,3 X Ø15 X 1 |
| HC193-S | WASHER Ø6,1 X Ø12 X 1 |

Ip/n from HC194-S to HC474-S | SPARE PARTS

| | |
|---------|---|
| HC194-S | WASHER Ø6,3 X Ø15 X 1 |
| HC200-S | METRIC HEX NYLON NUTS M2,5 H3,5 |
| HC206-S | METRIC HEX NYLON NUTS M3 H4 |
| HC212-S | METRIC HEX NYLON NUTS M4 H5 |
| HC218-S | METRIC HEX NYLON NUTS M5 H4,8 |
| HC224-S | METRIC HEX NUTS M8 H6,5 NYLON |
| HC228-S | SHIMS Ø8X Ø14 X 0,2 |
| HC230-S | SHIMS Ø10 X Ø16 X 1 |
| HC232-S | SHIMS Ø10 X Ø16 X 0,2 |
| HC234-S | SHIMS Ø10X Ø16 X 0,1 |
| HC235-S | TAIL PUSH ROD Ø4 X Ø2,5 X 596 (G500) |
| HC236-S | CF TAIL PUSH ROD Ø4 X Ø2,5 X 682 (G700 old) |
| HC237-S | CF TAIL PUSH ROD Ø4 X Ø2,5 X 635 (G630) |
| HC238-S | CF TAIL PUSH ROD Ø4 X Ø2,5 X 752 (G770) |

| | |
|---------|---|
| HC239-S | CF TAIL PUSH ROD Ø4 X Ø2,5 X 702 (G700 Com) |
| HC240-S | CF TAIL PUSH ROD Ø4 X Ø2,5 X 668 (G570) |
| HC242-S | THREADED RODS M2.5 X 40 X 3PCS |
| HC243-S | THREADED RODS M2 X 60 X 2PCS |
| HC304-S | TAIL BELT 700 2061-3-06 |
| HC308-S | MOTOR BELT 240-3-13 |
| HC309-S | MOTOR BELT 240-3-19 |
| HC315-S | SPRING DE 5,8 / DF 0,3 / LL 9 |
| HC316-S | SPRING for G500 |
| HC324-S | TAIL BELT 630 1926-3-06 |
| HC325-S | TAIL BELT 770 2160-3-06 |
| HC330-S | ORING DAMPER |
| HC335-S | ORING DAMPER |
| HC340-S | MOTOR BELT 195 - 3 - 9 |

| | |
|---------|--------------------------------|
| HC344-S | MOTOR BELT 204 - 3 - 9 |
| HC342-S | TAIL BELT 1530 - HTD - 4,5 |
| HC346-S | MOTOR BELT 240 - 3 - 9 |
| HC349-S | TAIL BELT 1632 - HTD - 6 |
| HC351-S | FLAT HEAD SOCKET CAP M4X6 |
| HC400-S | FLANGED BEARING Ø2,5 X Ø6 X2,6 |
| HC402-S | FLANGED BEARING Ø3 X Ø7 X3 |
| HC403-S | BEARING Ø4 X Ø9 X 2,5 |
| HC406-S | BEARING Ø5 X Ø9 X 3 |
| HC410-S | FLANGED BEARING Ø5 X Ø9 X 3 |
| HC411-S | BEARING Ø5 X Ø10 X 4 |
| HC412-S | FLANGED BEARING Ø5 X Ø13 X 4 |
| HC414-S | FLANGED BEARING Ø6 X Ø13 X 4 |
| HC416-S | FLANGED BEARING Ø7X Ø11 X 2,5 |

| | |
|---------|--------------------------------|
| HC417-S | BEARING Ø8 X Ø14 X 4 |
| HC418-S | FLANGED BEARING Ø8 X Ø12 X 3,5 |
| HC419-S | BEARING Ø8 X Ø16 X 5 |
| HC420-S | BEARING Ø10 x Ø15 x 4 |
| HC422-S | BEARING Ø10 X Ø19 X 5 |
| HC425-S | BEARING Ø12 X Ø18 X 4 |
| HC426-S | BEARING Ø12 X Ø24 X 6 |
| HC430-S | BEARING RAD. Ø30 X Ø37 X 4 |
| HC434-S | THRUST BEARING Ø4 X Ø9 X 4 |
| HC435-S | THRUST BEARING Ø5X Ø10 X 4 |
| HC437-S | THRUST BEARING Ø8X Ø14 X 4 |
| HC438-S | THRUST BEARING Ø10X Ø18 X 5,5 |
| HC440-S | ONE WAY BEARING Ø8 X Ø12 X 12 |
| HC442-S | ONE WAY BEARING Ø10 X Ø14 X 12 |

| | |
|---------|--|
| HC448-S | THRUST BEARING Ø3X Ø6X2.5 |
| HC453-S | ORING MAIN AND TAIL ROTOR |
| HC451-S | CF TAIL PUSH ROD Ø4 X Ø2,5 X 854 (GUrukay) |
| HC454-S | BELT 304-2GT-09 |
| HC455-S | BELT 1140-HTD-2 |
| HC456-S | FLANGED BEARING 2X 5X2.5 |
| HC457-S | BEARING Ø3Ø6X2.5 |
| HC458-S | BEARING Ø3Ø7X3 |
| HC459-S | RADIAL BEARING 25 x 32 |
| HC461-S | TAIL PUSH ROD Ø4 X Ø2,5 X 420 (380) |
| HC462-S | SHIM 8x12x0,1 |
| HC472-S | MOTOR BELT 339-3GT-013 |
| HC473-S | SILICONE TUBE 2,5x5,5 |
| HC474-S | SILICONE TUBE 2,5x4,5 |



The most beautiful 2015 pictures



SAB HELI DIVISION YOUTUBE CHANNEL





SAB HELIDIVISION AUSTRIA

HELI-SHOP.COM GOBLIN-HELICOPTER.EU



 <https://www.facebook.com/sabhelidivision>



www.goblin-helicopter.com
support@goblin-helicopter.com
sales@goblin-helicopter.com



www.sabitaly.it
support@sabitaly.it
sales@sabitaly.it

